



National Kaohsiung
CENTER FOR THE ARTS

WEI WU YING 

衛武營 國家藝術文化中心

國家表演藝術中心 National Performing Arts Center

PLAYHOUSE

Technical Information

Table of Contents

1 General Information	2
1-1 National Kaohsiung Center for the Arts (WeiWuYing)	2
1-2 PlayHouse	2
1-3 Traffic Information	3
1-4 Contact Information	3
1-5 Stage door	3
1-6 Auditorium / Seats	4
1-7 Plan	6
1-8 Section	8
2 Stage	9
2-1 Stage	9
2-2 Elevation Platform / Stage Traps	10
2-3 Traps	13
2-4 Tension Grid	13
2-5 Fly	14
2-6 Hoisting	15
2-7 Curtain and Others	16
2-8 Fly Bar List	17
3 Lighting	19
3-1 Lighting instrument	19
3-2 Accessories	20
3-3 Lighting DMX system	22
3-4 Lighting Circuit	23
3-5 Portable Lift	30
3-6 Additional Power Supply	30
3-7 Working Light / House Light	30
4 Audio/Video-Systems	31
4-1 Audio Facilities	31
4-2 Control Room	36
4-3 Stage Manager' s Console	36
4-4 Microphone	37
4-5 Communications	37
4-6 Locations of Communications	38
4-7 Stage Cameras and Video Surveillance Systems	38
4-8 Paging Systems	39
4-9 Projector	40
4-10 Subtitle	41
5 Backstage	42
5-1 Dressing Room and Green Room \ Company office	42
5-2 Orchestra Facilities	42
5-3 Pianos (shared between four theatres)	43
5-5 Other Facilities	46

Last updated: 2025/1/25

1 General Information

1-1 National Kaohsiung Center for the Arts (WeiWuYing)

CENTER FOR THE ARTS, ARTS FOR THE PEOPLE, National Kaohsiung Center for the Arts will become one of the important theatre complexes of the international art field. It include four performance blocks, the 2,236 seat Opera House, the 1981 seat Concert Hall, the 1210 seat Play House and the 434 seat Recital Hall.



1-2 PlayHouse

The Playhouse is a space mainly used for various drama and dance performances. The stage can be configured into proscenium or thrust stage. The thrust stage design shortens the distance between the audience and performers, so that the audience can perceive the emotions of the performers at close proximity.



1-3 Traffic Information

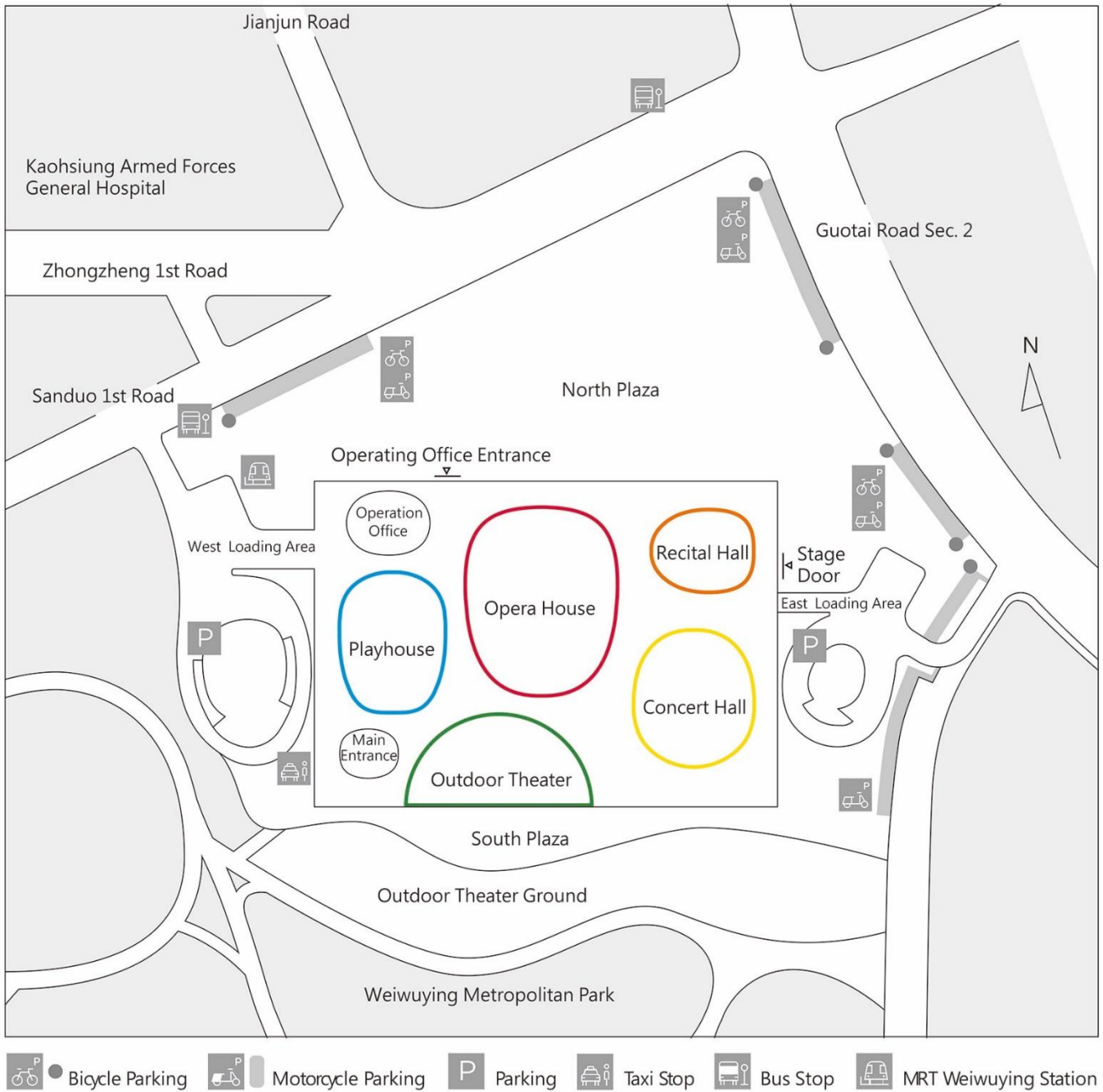

1-4 Contact Information

National Kaohsiung Center for the Arts (Weiwuying)

No.1, Sanduo 1st Rd., Fengshan Dist.,
Kaohsiung City 83075, Taiwan

+886 7-262-6666

service@npac-weiwuying.org

1-5 Stage door

Ground floor access is from the north and east side of building. Enter from Operating office entrance on Sanduo 1st Road or Stage Door on Guotai Road.

Basement Level 1 access is from Sanduo 1st Road entrance for Opera House and Playhouse, Guotai Road entrance for Concert Hall and Recital Hall.

Working pass will be required for entry.

1-6 Auditorium / Seats

2021/05/13

Seating Capacity : 1209 seats

- House Seats : 876 seats (1F/167 seats ~ 2F/502 seats ~ 3F/207 seats)
- Wheelchairs Seats : 13 seats
- Companion Seats : 13 seats
- Orchestra Pit Seats : 164 seats
 - Elevation Platform No.1 (Row 1, NO.1~23 ~ Row 2, NO.1~24) : 47 seats
 - Elevation Platform No.2 (Row 3, NO.1~23) : 23 seats
 - Elevation Platform No.3 (Row 4, NO.1~22) : 22 seats
 - Elevation Platform No.4 (Row 5, NO.1~21) : 21 seats
 - Elevation Platform No.5 (Row 6, NO.1~18) : 18 seats
 - Elevation Platform No.6 (Row 7, NO.1~17) : 17 seats
 - Elevation Platform No.7 (Row 8, NO.1~16) : 16 seats
- Chinese Orchestra Pit Seats (Side Auditorium Platform) : 48 seats
 SAP(Row 9, NO.22~40 ~ Row 10, NO.24~44 ~ Row 11, NO.26~48 ~ Row 12, NO.28~56) : 48 seats
- Control Area Seats : 16 seats
- Reserved Seats for Tech Table : 4 seats
- Reserved Seats for FOH : 7 seats
- Obstructed View Seats : 16 seats (Non-ticketing) Proscenium Stage Obstructed View Seats : 172 seats
- Partial View Seats : 52 seats (Tickets can be sold, and "Partial View" must be marked)
- Reserved Seats

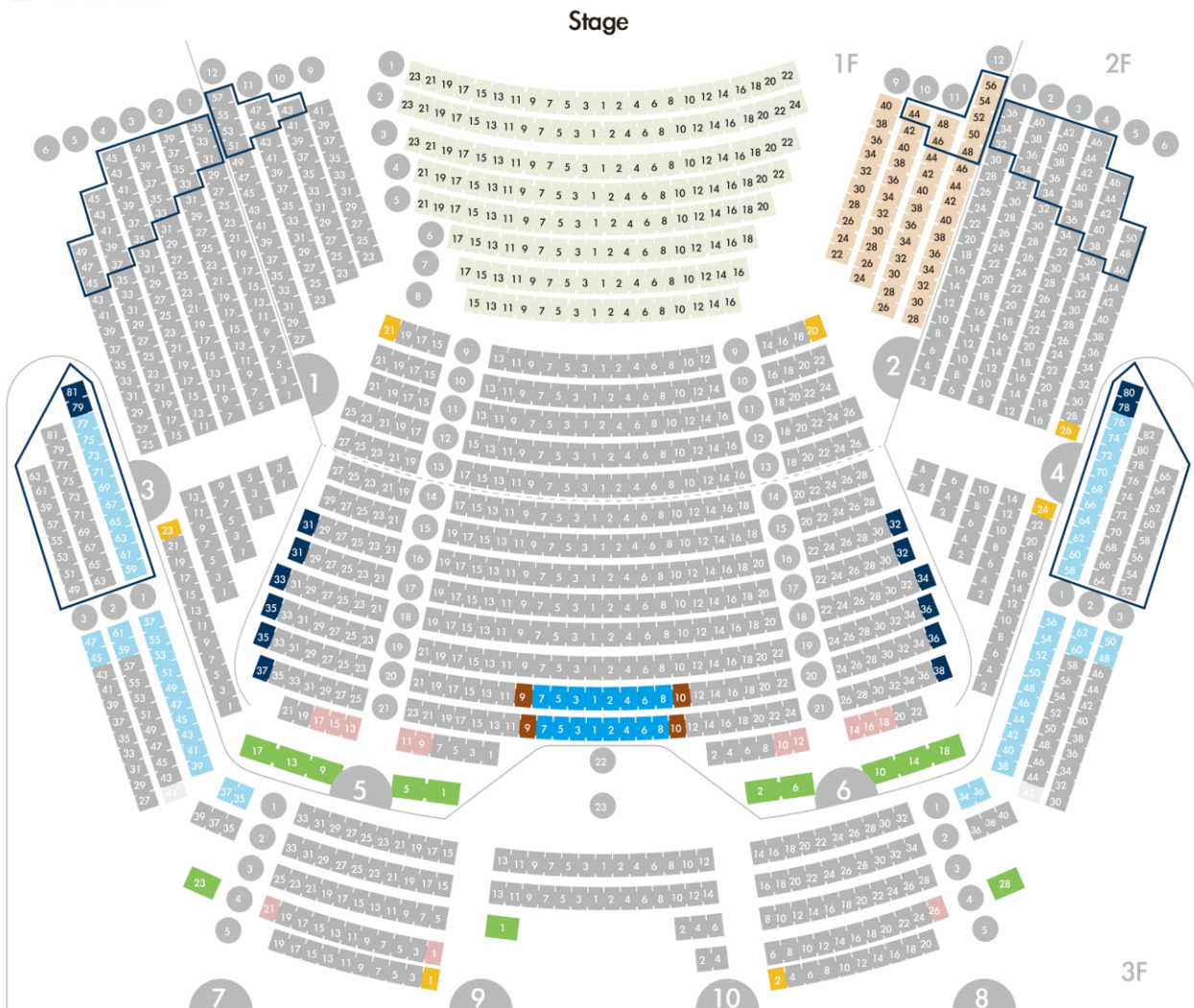

Figure 1.1- Seats plan

Set Up Equipment Recommended Seat

Set Up Equipment Seat	Reserved Seat	Notes
2nd Floor 14 row Seat 27	1st Floor 13 row Seat 25、27 2nd Floor 14 row Seat 23、25 2nd Floor 15 row Seat 27、29	For Photo Shooting & Video Shooting
2nd Floor 14 row Seat 28	1st Floor 13 row Seat 24、26 2nd Floor 14 row Seat 24、26 2nd Floor 15 row Seat 26、28	For Photo Shooting & Video Shooting
2nd Floor 20 row Seat 1	2nd Floor 19 row Seat 1、2 2nd Floor 20 row Seat 2、3 2nd Floor 21 row Seat 1、2、3	For Photo Shooting & Video Shooting
Set Up Control Area	Reserved Seat	Notes
2nd Floor 20 row Seat 1~8 2nd Floor 21 row Seat 1~8	2nd Floor 20 row Seat 9、10 2nd Floor 21 row Seat 9、10	
1st Floor 12 row Seat 27 1st Floor 12 row Seat 28	1st Floor 11 row Seat 23、25 1st Floor 12 row Seat 29、31 1st Floor 11 row Seat 26、28 1st Floor 12 row Seat 30、32	Suggested Location for Subtitle Projector.
1st Floor 12 row Seat 46 1st Floor 12 row Seat 47	1st Floor 11 row Seat 36~48 1st Floor 12 row Seat 28~56 1st Floor 11 row Seat 35~47 1st Floor 12 row Seat 27~57	Suggested locations for using the 6000 lumen laser projector in the venue.

1-7 Plan

戲劇院一樓化妝室位置圖

Playhouse 1F Dressing Room Map

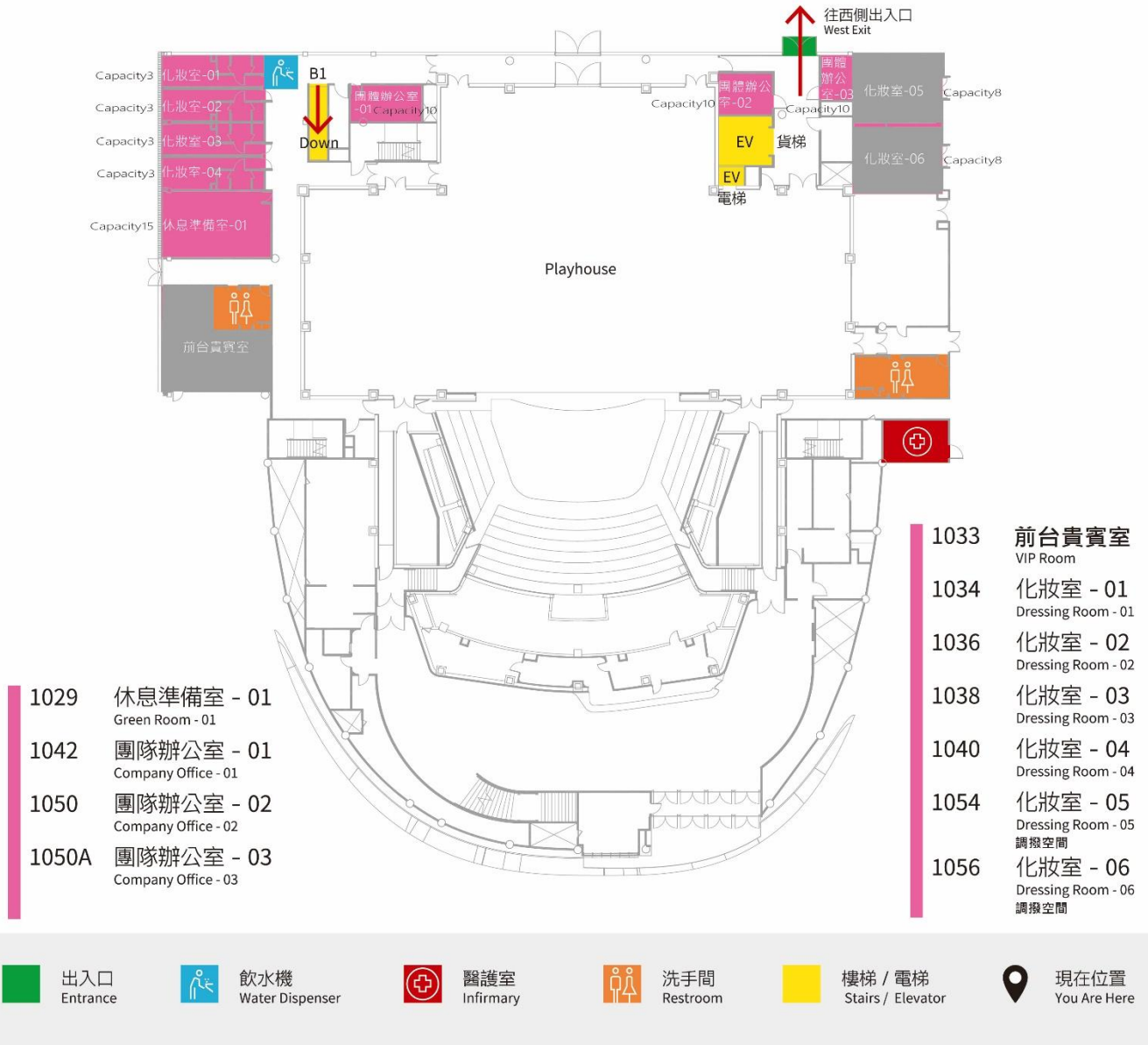

Figure 1.2- Playhouse 1F Plan

戲劇院地下一樓化妝室位置圖

Playhouse B1F Dressing Room Map

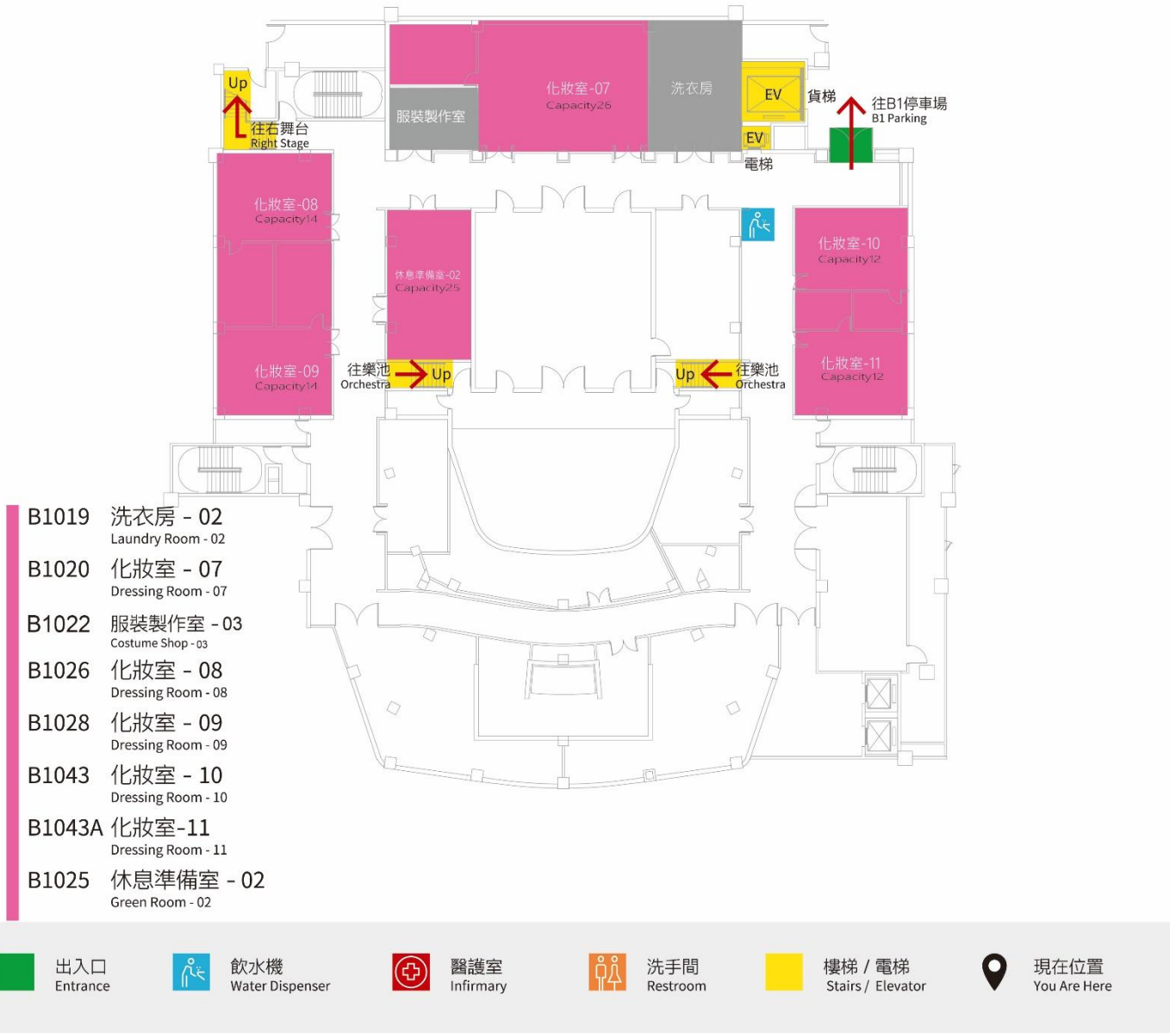

Figure 1.3- Playhouse B1F Plan

1-8 Section

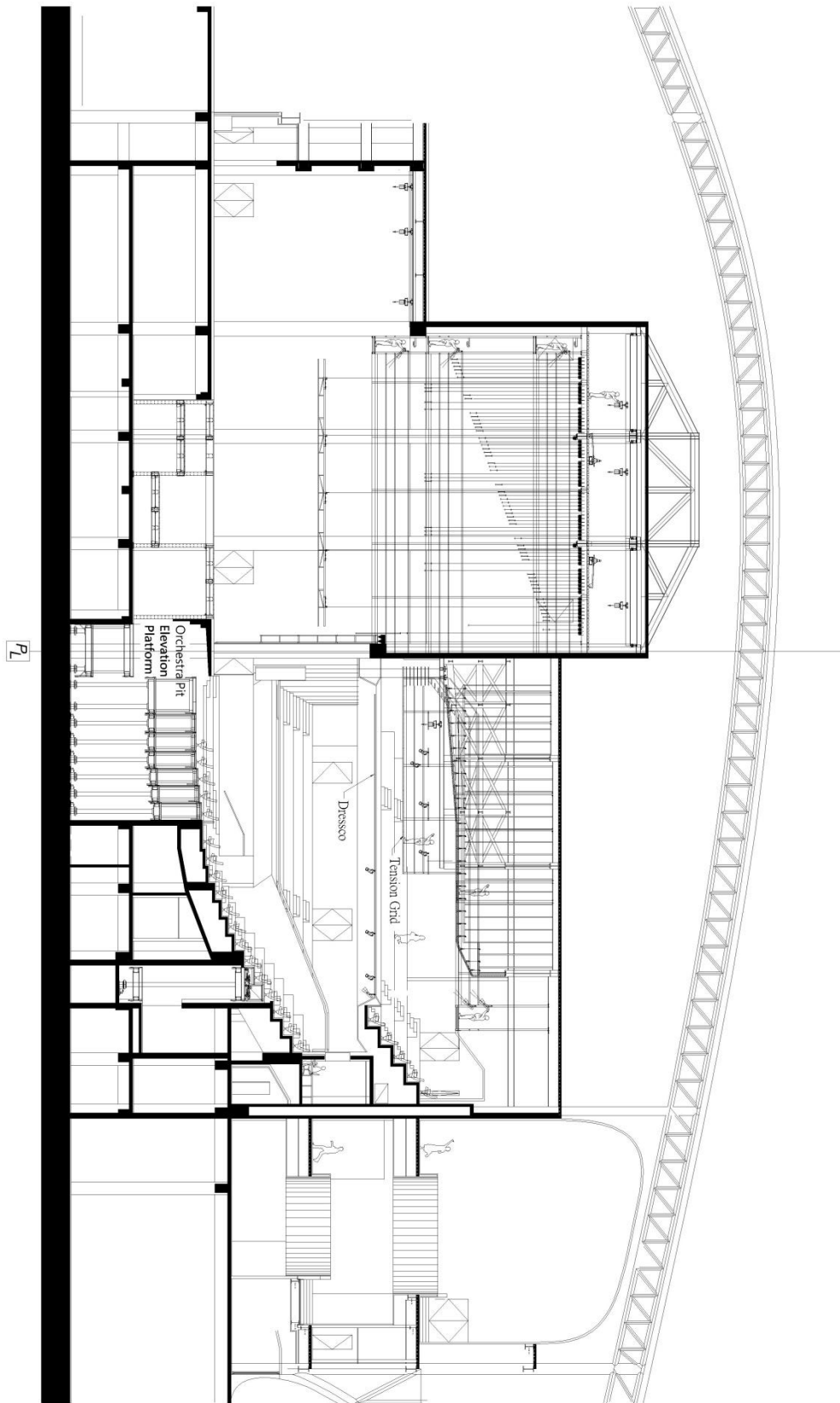

Figure 1.4- Playhouse Section

2 Stage

2-1 Stage

2-1-1 Floor

Black painted composite wood stage floor, The production scenery can secure to the deck by screws but no nails in part of stage area. Please contact the technical service for more detail.

The trap area is made of Okoume hardwood plywood, the surface is prohibited from nailing and locking.

The main stage, side stage, rear stage, pit elevation platform, the auditorium elevation platform is made of Pitch pine, the stage surface can be locked with screws, and can not be drilled.

2-1-2 Tormentor

Proscenium size : 18m (width) x 8m (height)

Proscenium opening: 12m to 18m (width)

Apron to PL: 1.8m

2-1-3 Stage Dimensions

Main stage: 27.2m (width) x 16.2m (depth) x 20.5m (height) (from stage surface to under above grid beams)

Rear stage: 22.3m (width) x 10m (depth) x 11m (height) (8.5m height from stage surface to under gallery)

Side stage: 10.2m (width) x 16.2m (depth) x 11m (height) (8.5m height from stage surface to under gallery)

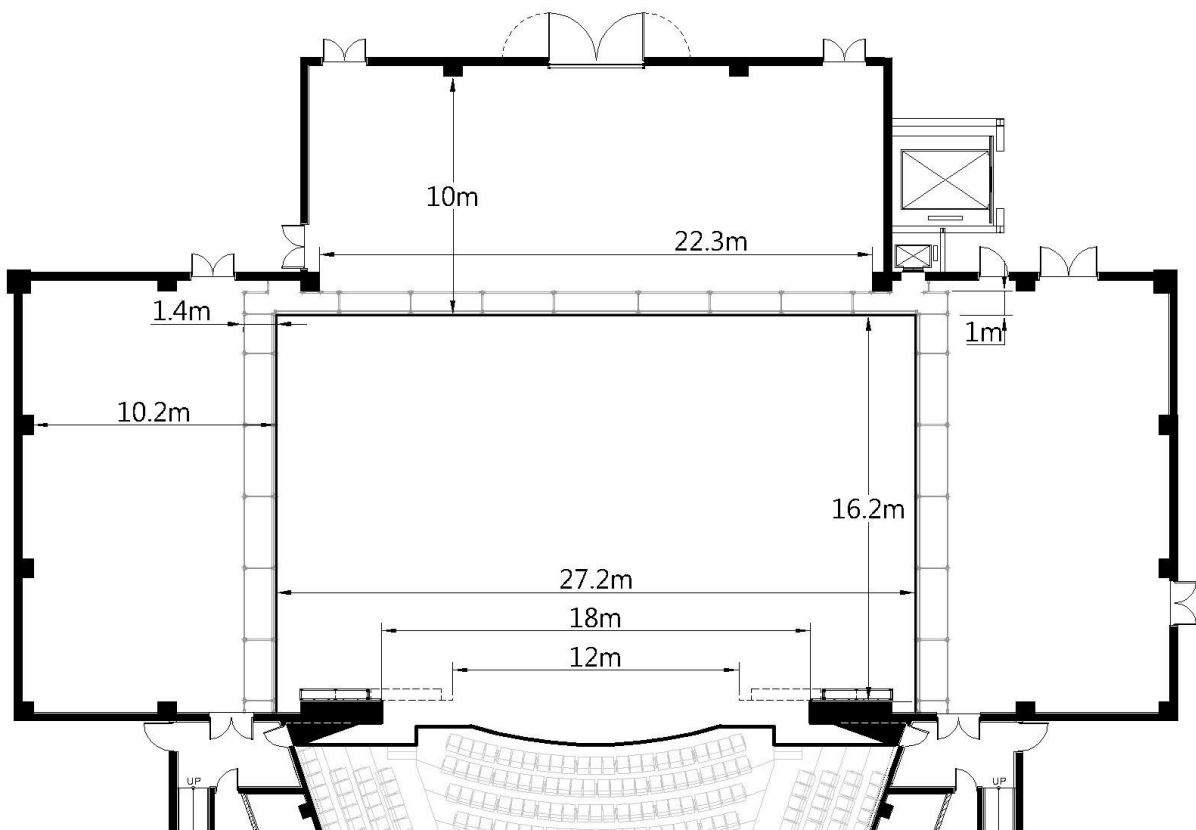

Figure 2.1- Stage Plan

2-2 Elevation Platform / Stage Traps

2-2-1 Orchestra Pit

Orchestra pit may combined with elevation platform No.1 and 2, as the extend.

Amount: 1 row, arc shape platform

Size: 15m (width) x 2.85m (depth), 38.5 m²

Elevation: -4.5m to -2.25m

Capacity

Dead load : 500kg/ m²

Live load : 250kg/ m²

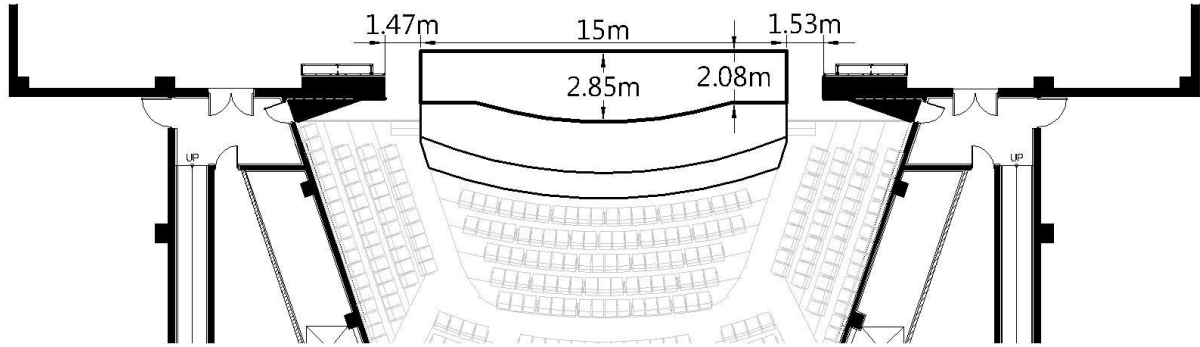

Figure 2.2.1.1- Orchestra Pit Elevation Platform location plan

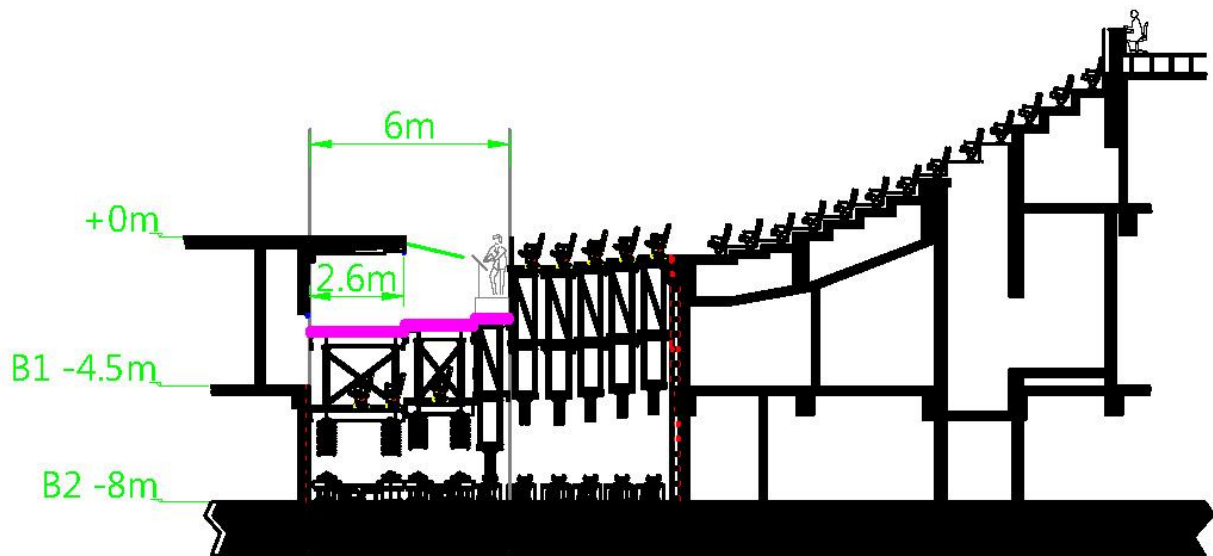

Figure 2.2.1.2- Orchestra Pit Elevation Platform Section

2-2-2 Elevation Platform

Elevation Platforms can be adjust for different function, as auditorium, thrust stage and extend orchestra pit (No.1 · 2 · 3) by need.

- No.1, 15 m (width) x 2.1m (depth), 31.2 m²
- No.2, 15m (width) x 1.05m (depth), 16 m²
- No.3, 14.6m (width) x 1.05m (depth), 15 m²
- No. 4, 13.8m (width) x 0.95m (depth), 12.7 m²
- No.5, 13m (width) x 0.95m (depth), 11.9 m²
- No.6, 12.3m (width) x 0.95m (depth), 11.2 m²
- No.7, 11.6m (width) x 1m (depth), 9.9 m²

Elevation

- No.1 : -4.5m to 1.65m
- No.2~ No.7: -3.3m to 1.65m

Capacity

- Dead load : 500kg/ m²
- Live load : 250kg/ m²

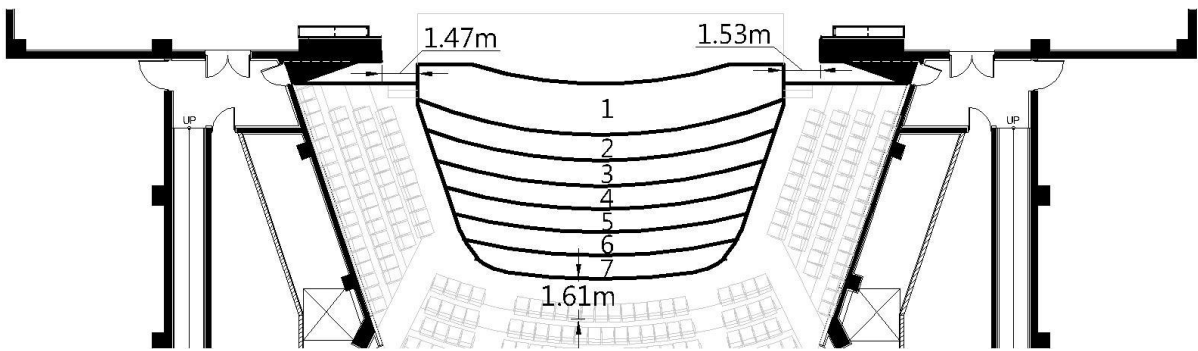

Figure 2.2.2- Elevation Platform location plan

2-2-3 Chinese Orchestra Pit (Side Auditorium Platform)

- SAP-1: 8m (width) x 0.95m (depth), 6.9 m²
- SAP-2: 9.25m (width) x 0.95m (depth), 8 m²
- SAP-3: 10.6m (width) x 1m (depth), 9.6 m²

Elevation

- SAP-1: -0.6m to 0.3 m
- SAP-2/ SAP-3 : -0.6m to ±0.0m

Capacity:

- Dead load : 500kg/ m²
- Live load : 250kg/ m²

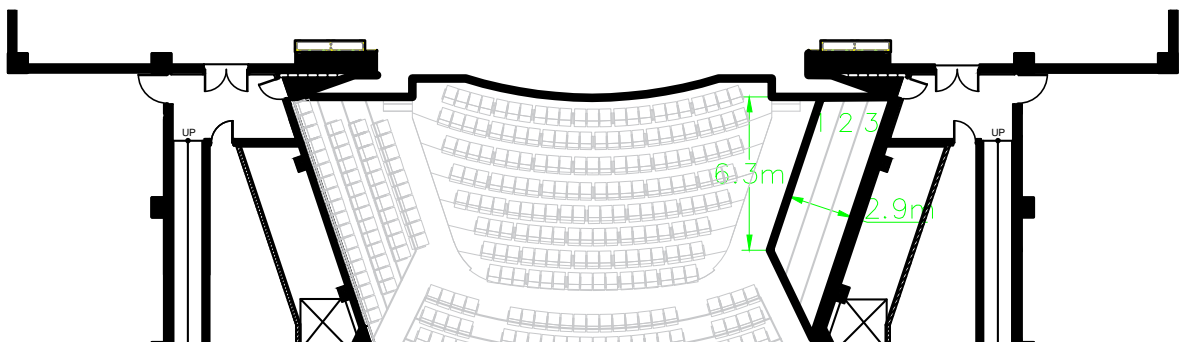

Figure 2.2.3- Chinese Orchestra Pit (Side Auditorium Platform) location plan

2-2-4 Auditorium Control Area

16 Seats, No.1~8, Row 17 ~18

For large equipment, please enter the platform from B1 floor.

Size: 4.7m (width) x 2.1m (depth), 9.87 m²

Elevation: -4m (B1) to 2.8m

Capacity

Dead load : 500kg/ m²

Live load : 250kg/ m²

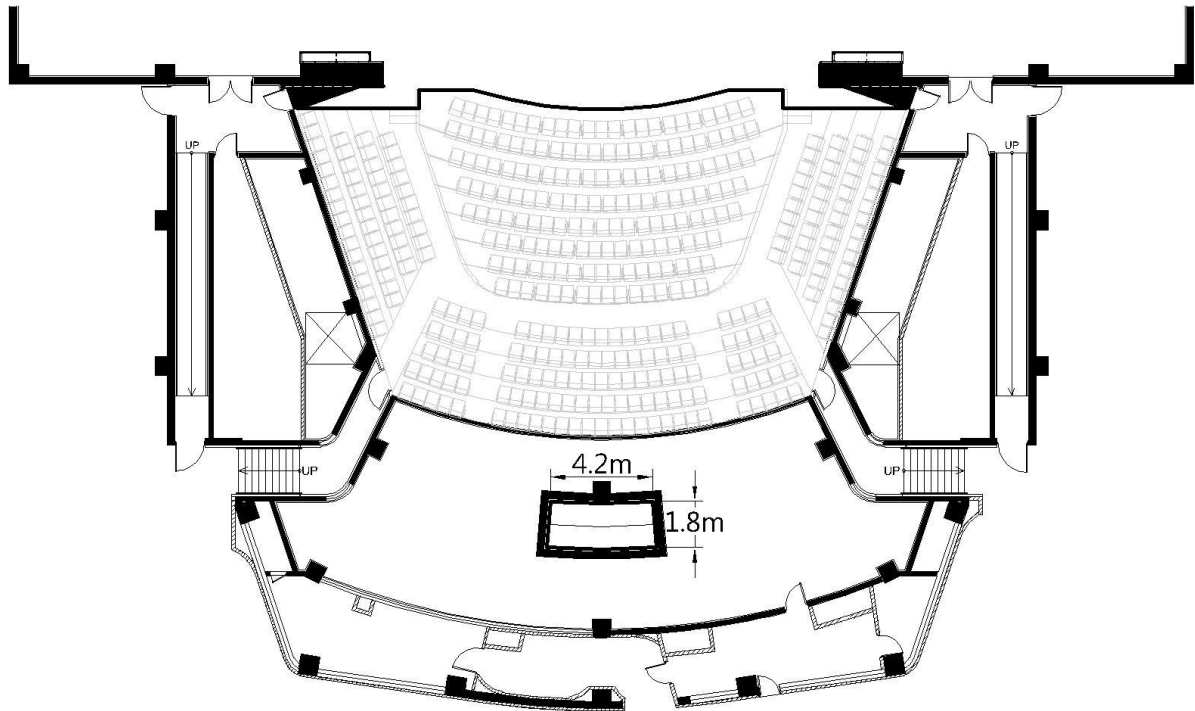

Figure 2.2.4- Auditorium Control Area location plan

2-3 Traps

72 pieces individual trap door

Size: 11.4m x 11.4m / 0.95m (width) x 1.9m (depth) each

Capacity: 500kg/ m², average

Distance to PL : 1.87m

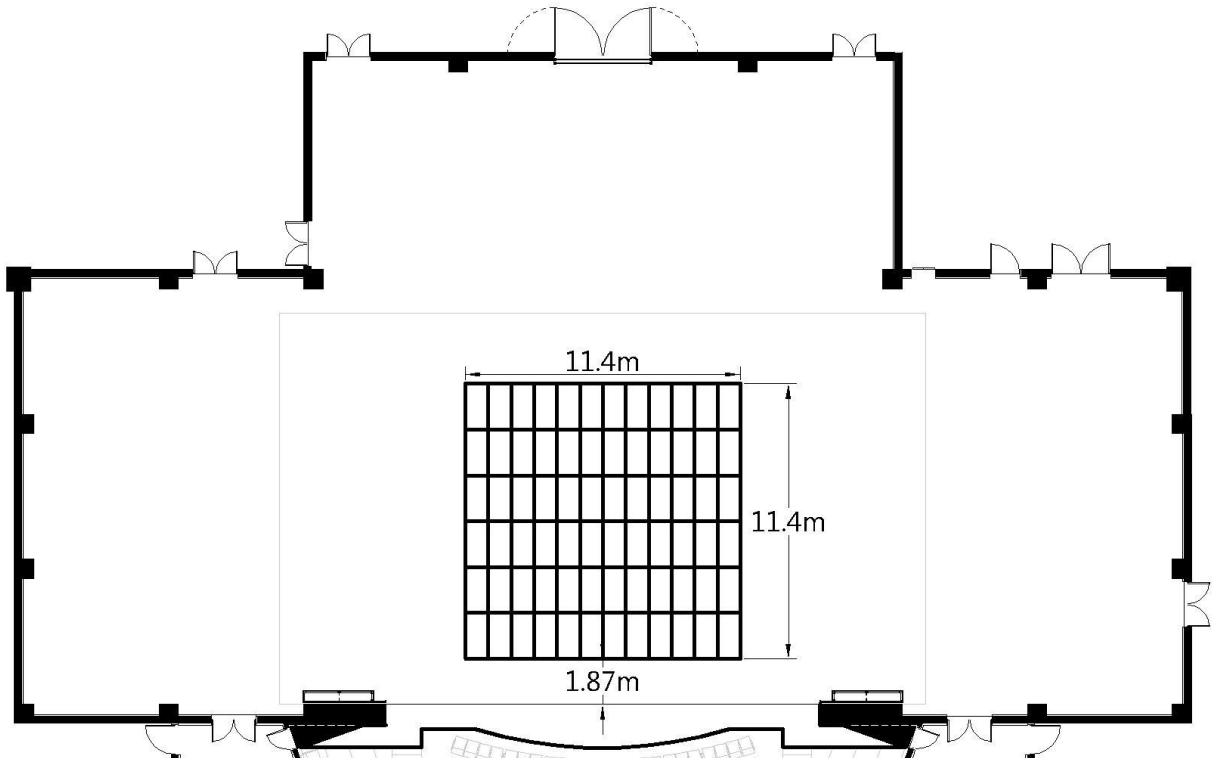

Figure 2.3- Stage Traps location plan

2-4 Tension Grid

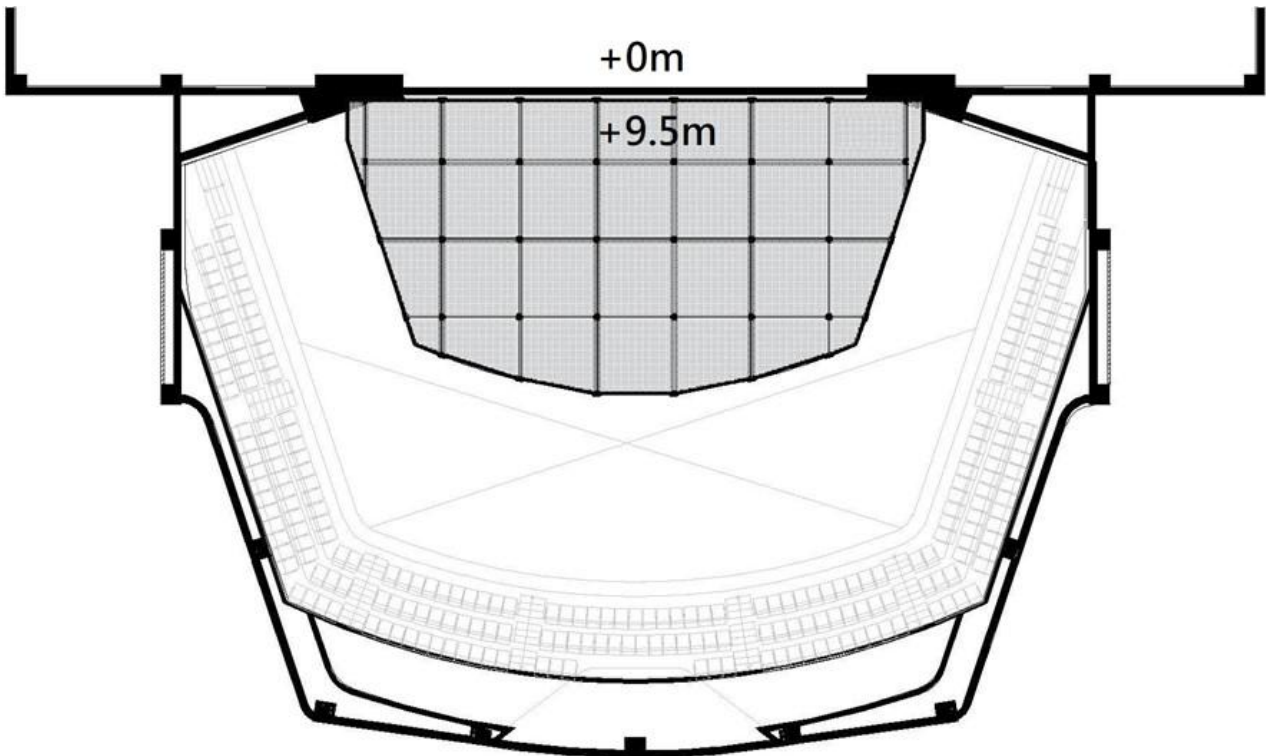

Figure 2.4-

Tension Grid location plan

2-5 Fly

2-5-1 Controller

Waagner Biro CAT120、CAT190、CAT192

2-5-2 Main Stage Fly bars

22m (length), 4.8cm (diameter), +0.05m to 19m, 67 sets

Safe load

1.8 m/s : 350kg

1 m/s : 750kg

2-5-3 House Curtain

House Curtain, guillotine 24m (length), + 0.05m to 19m

Safe load

2.4 m/s : 350kg

1.8 m/s : 500kg

2-5-4 Side Fly Bar (2 on both side)

Side Fly Bar 1, 14.4m (length), 11.8m from CL, +0.05m to 19m

Side Fly Bar 2 / 3, 14.9m (length), 12.2 / 12.6 from CL, +0.05cm to 19m

Capacity: 750kg

Safe load

1.8 m/s : 350kg

1m/s : 750kg

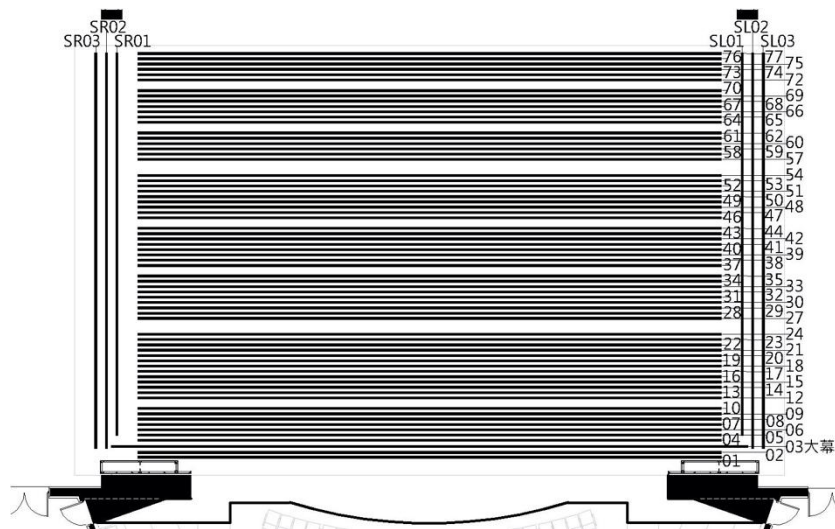

Figure 2.5.1- Fly Bars Plan

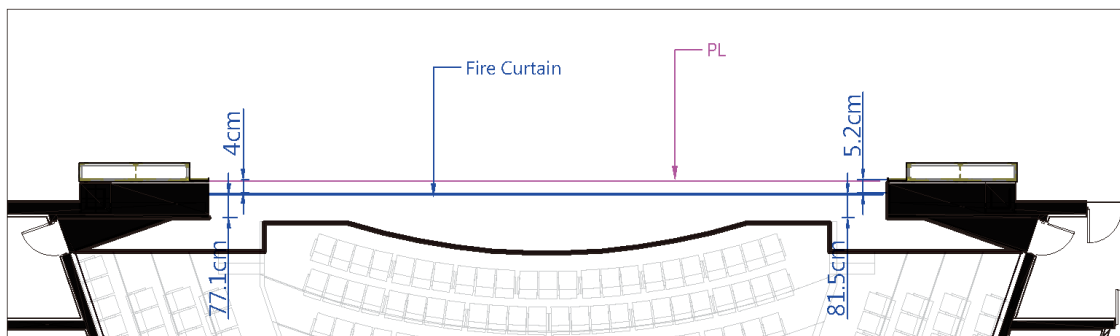

Figure 2.5.2- Fire Curtain

※ Area underneath the fire curtain must stay clear to allow the curtain to fall into position. Without advanced permission, to set any scenic pieces in this area is strictly prohibited. Only when permitted by the house, the units that could be removed rapidly or damaged can be on the deck. If there is circuit that must go through the area, we accept flat tapping down the cables, and unplugging the instruments before leaving.

2-6 Hoisting

2-6-1 Point Hoist (load 250kg)

8 sets, winch line length 31.2m, lifting speed: 0 to 1.2m/s

Operation range : available for using on grid area. Boundless except for Fly Bars operation space.

Capacity load : 250kg

2-6-2 Chain Hoist with Trolley

Comply safety regulations : BGV-C1 、 EN 61508 、 DIN 56950

Capacity load : 1000kg

fixed speed : 0.16m/sec

Grid : 12 sets, operation length 28m (Boundless except for Fly Bars operation space)

Rear stage : 12 sets, operation length 12m

Tension Grid : 5 sets, operation length 21m

2-6-3 D8 Plus Chain Hoist

Comply safety regulations : BGV-C1 、 EN 61508 、 DIN 56950

Capacity load : 1000kg

fixed speed : 0.16m/sec

Side stage: 6 sets, operation length 12m

2-6-4 Hoist for Subtitle Display (load 500kg)

2 sets, -1m to 19m

lifting speed: 0 to 0.5m/s

Capacity load : 250kg

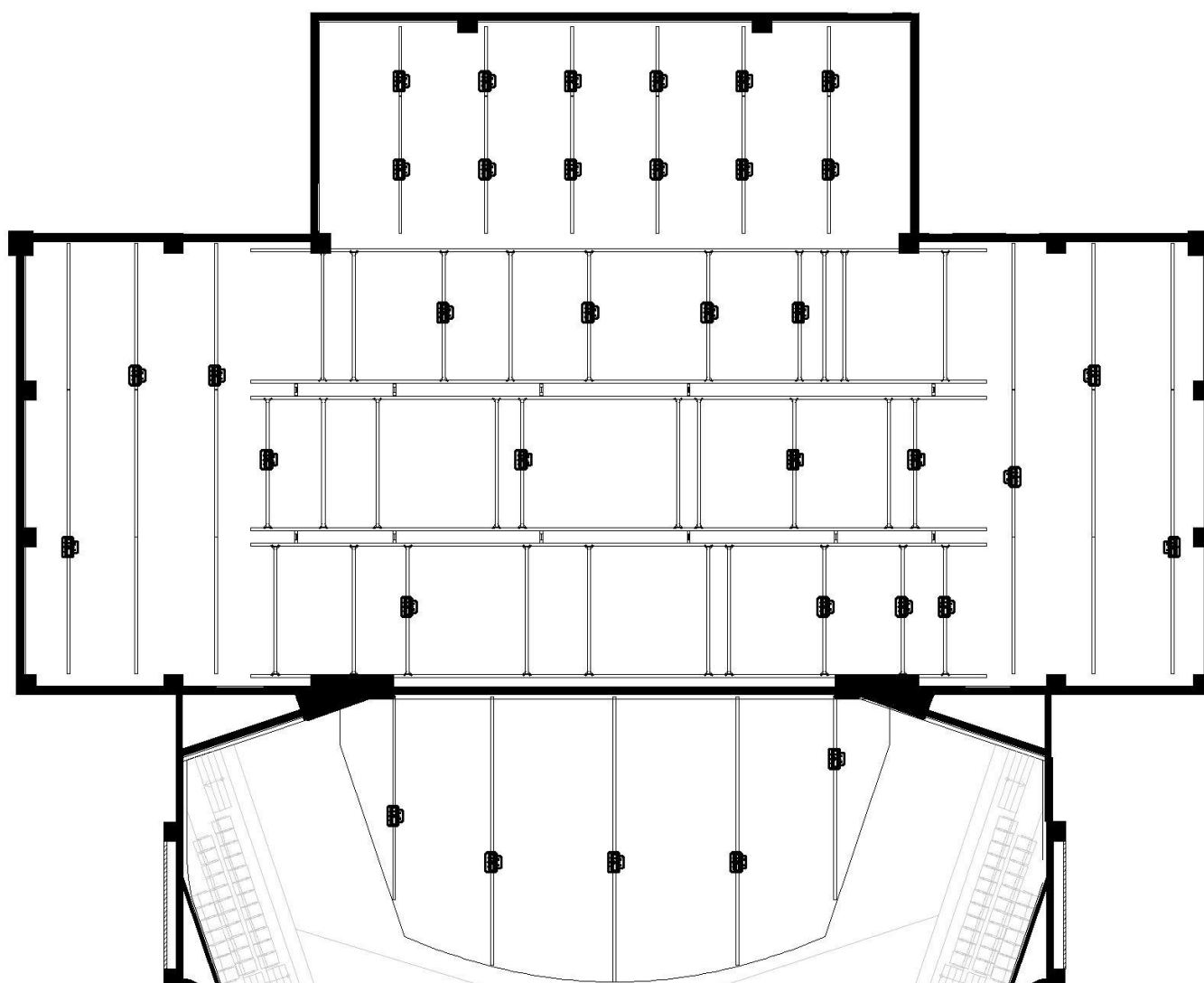

Figure 2.6- Chain Hoisting plan

2-7 Curtain and Others

Item Number	Product Name	Quantity	Notes (unit: meter)	Paid Item
01	House Curtain	1 pair	10 x 12.9 ShowTex –Paris CS (Black color)	
02	Border	8 pc	3.5 × 22 ShowTex –Bellini	
03	Leg	10 pc	9 × 2.7 ShowTex –Bellini	
04	Leg	22 pc	9 × 4 ShowTex –Bellini	
05	Tab	8 pc	8.8 × 3 ShowTex –Bellini	
06	Black Front and Rear Projection Screen		3 Choices of Screens: Black : ShowTex – Retro Screen Black 9× 21.5 Grey : ShowTex – Retro Screen Grey plus 9 × 22 Grey : Gerriets t 21240000 (Grey) 12.9 x 7	* The first piece is rent-free. The second piece will be charged. Please refer to the rate tables of National Kaohsiung Center for the Arts. The third piece of projection screen shared with Playhouse.
07	Scrim	1 pc	10 × 22 ShowTex - Sharks Tooth Scrim 6 point Shark tooth in white 6pt x 1 、 Shark tooth in black 6pt x 1 、 Shark tooth in black 8pt x 1	*
08	Cotton Cyclorama	1 pc	10 × 22 ShowTex –Cyclo 270	
09	Black Backdrop	1 pc	9 × 22 ShowTex –Bellini	
		2 pc	10 × 9 ShowTex –Bellini	
10	Wooden Sprung Floor 2m*1m	152 pc	1.Shared with Opera House 2.Area (installation area adjustable) 20m x 16m, built-up, portable with latch, wooden plywood with high density mitigation block, 3.7 cm (depth),point load 1000kg, average shock-absorbing ability 65 %	
11	Wooden Sprung Floor 1m*1m	16 pc		
12	Black Dance Floor For Wooden Floor only	8 rolls	1.Shared with Opera House 2.20m (length) x 2m (width) x 2mm (depth)	
13	Black and White Dance Floor	18 rolls	18m (length) x 0.9m (width) x 1.8mm (depth)	
14	Black and Gray Dance Floor	18 rolls	1.Shared with Opera House 2.20m (length) x 2m (width) x 1.7mm (depth)	
15	Hydraulic Lift Platform(for Orchestra Pit)	1	1. 1.8 M(length) x 0.9 M (width) 、 Elevation : 1 M-1.5 M 2. Shared with Opera House	*

Items with * mark are paid items. Please refer to the rate tables of National Kaohsiung Center for the Arts.

2-8 Fly Bar List

Bar Number	Distance to PL	Content	Length (cm)	Bar Number	Distance to PL	Content	Length (cm)
PL							
FLYBARS_STAGE. / High limitation : 19m low limitation : 1.25m							
FB01	67		2200	FB40	853		2200
FB02	87		2200	FB41	872		2200
FB03	110	HOUSE_CURTAIN Guillotine	2400	FB42	890		2200
FB04	133		2200	FB43	915		2200
FB05	152		2200	FB44	931		2200
FB06	171		2200	FB45			2200
FB07	190		2200	FB46	970		2200
FB08	212		2200	FB47	991		2200
FB09	232		2200	FB48	1013		2200
FB10	251		2200	FB49	1031		2200
FB11			2200	FB50	1051		2200
FB12	292		2200	FB51	1069		2200
FB13	312		2200	FB52	1092		2200
FB14	330		2200	FB53	1112		2200
FB15	353		2200	FB54	1130		2200
FB16	373		2200	FB55			2200
FB17	392		2200	FB56			2200
FB18	410		2200	FB57	1190		2200
FB19	433		2200	FB58	1211		2200
FB20	452		2200	FB59	1230		2200
FB21	471		2200	FB60	1250		2200
FB22	492		2200	FB61	1270		2200
FB23	512		2200	FB62	1290		2200
FB24	529		2200	FB63			2200
FB25			2200	FB64	1330		2200
FB26			2200	FB65	1350		2200
FB27	593		2200	FB66	1370		2200
FB28	612		2200	FB67	1390		2200
FB29	633		2200	FB68	1412		2200
FB30	651		2200	FB69	1431		2200
FB31	673		2200	FB70	1453		2200
FB32	692		2200	FB71			2200
FB33	711		2200	FB72	1493		2200
FB34	733		2200	FB73	1512		2200
FB35	751		2200	FB74	1532		2200
FB36			2200	FB75	1553		2200
FB37	792		2200	FB76	1571		2200
FB38	812		2200	FB77	1591		2200
FB39	833		2200				

FLYBARS_SIDE / High limitation : 19m low limitation : 1.25m							
SFB-1L	1180		1440	SFB-1R	1180		1440
SFB-2L	1219		1490	SFB-2R	1219		1490
SFB-3L	1259		1490	SFB-3R	1259		1490
HOIST FOR SUBTITLE							
HS-01				HS-02			
ORCHESTRA & AUDITORIUM PLATFORM							
OP				AP04			
AP01				AP05			
AP02				AP06			
AP03				AP07			
SOUND MIXER & SIDE AUDITORIUM PLATFORM							
MIX				SAP02			
SAP01				SAP03	-		

3 Lighting

3-1 Lighting instrument

Item	Position	Model	Specification	Quantity	Frame Size	Note	Paid Item	
Lighting Console	Control Booth	GrandMA 2 Light		1				
	Auditorium			1				
Dimmer System		State Automation Solution	220V 3kW/Circuit	536ch				
			220V 5kW/Circuit	30ch				
Ellipsoidal Reflector Spotlight	Catwalk	ETC Source Four 10°	220V/800W	14	30.5x30.5cm			
		Selecon SPX 14°		18	15.8x15.8cm			
	Tension	ETC Source Four 10°	220V/800W	5	30.5x30.5cm			
		Selecon SPX 14°		10	15.8x15.8cm			
		Selecon SPX 19°		30				
		Selecon SPX 15°-35°		10				
			Selecon SPX 14°	220V/800W	6	15.8x15.8cm		
			Selecon SPX 19°		40			
			Selecon SPX 26°		70			
			Selecon SPX 36°		48			
			Selecon SPX 15°-35°		15			
			ETC Souce Four 50°	220V/750W	20	15.9x15.9cm		
	2KW Fresnel Spotlight 8"	Side Stage	Selecon Arena Theatre 8" Fresnel 7°-60°	220V/2kW	70	24.5x24.5cm		
Parabolic Aluminized Reflector Spotlight	PAR 64-Kupo PL-64LB		220V/1kW	96	25.4x25.4cm	Lamp : W x 16 、 M x 32 、 N x 32 、 VN x 16		
CYC Light	Selecon Aurora 4-Cell Linear CYC		220V/1kW	12	30.5x31.5cm			
Ground Row	Selecon Aurora 3-Cell Linear GroundRow	12						
Long Throw Follow Spot	Follow Room	Lycian M2 Model 2040 1.2	220V/1.2kW	2				
HMI Fresnel Spotlight 12"	Storage	ARRI D40 HMI Fresnel	220V/4kW	4	With Douser (Note 1)	If Strip manual needed, please contact TC Team.	*	
Strip Light		Selecon PL TR2 RGB 18 Striplights	110-220V/ 2.5A-1.3A 280W	8			*	
Fog Machine		Antari F-5D	220V/3.6A 810W	2			*	
Haze Machine		Antari HZ-500	220V/2A 480W	2			*	
Effect Fan		Antari AF-4	220V/0.48A 115W	4			*	
Kupo kupole extends			Extends from 210cm to 370cm.Max weight 12Kg		1			*

Items with * mark are paid items. Please refer to the rate tables of National Kaohsiung Center for the Arts.

Note 1_Brand : Teclumen

Model : Lite dim DMX dia 380mm

3-2 Accessories

Item	Specification	Size	Quantity
Barn Door	2kW Fresnel		30
Iris	For Selecon Ellipsoidal Reflector Spotlight		50
Gobo Holder	For Selecon Ellipsoidal Reflector Spotlight	B Size	70
	For ETC Source Four Ellipsoidal Reflector Spotlight	A Size	30
Power Distribution Box	8CIR CEE Form Female Plug 		40
Multi-Cable	16pin Multi Cable Harting Connector	5m	24
		10m	20
		15m	10
Ex-Cable	CEE16A	1.5m	40
		2m	60
		3m	30
		5m	45
		10m	40
		15m	40
Y-Cord	CEE16A Parallel Cord		40
Adapter Cable	CEE 16A(M) To Stage-Pin(F)		50
Boom Base	Boom Base & Pipe	Boom Base:45cm(W)x60cm(L) Pipe:300cm	12

Portable Sidelight Tower

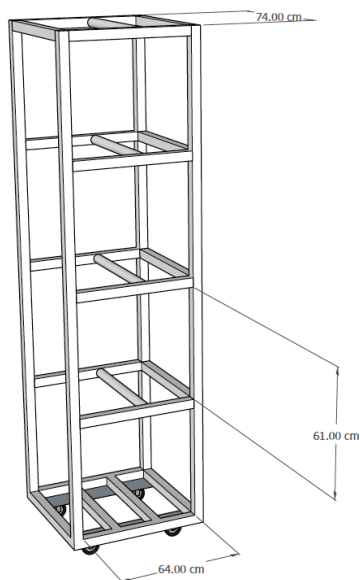

74cm(W)x74cm(L)x280cm(H)

10

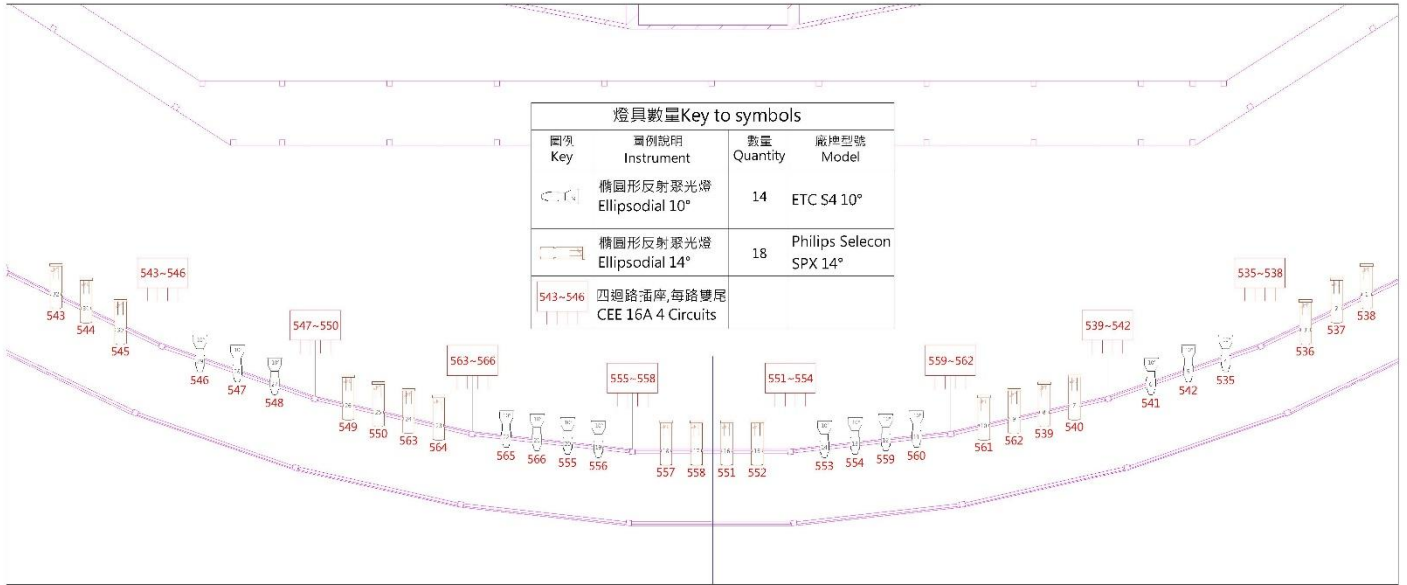

Figure 3.2.1- FOH Lighting Plot

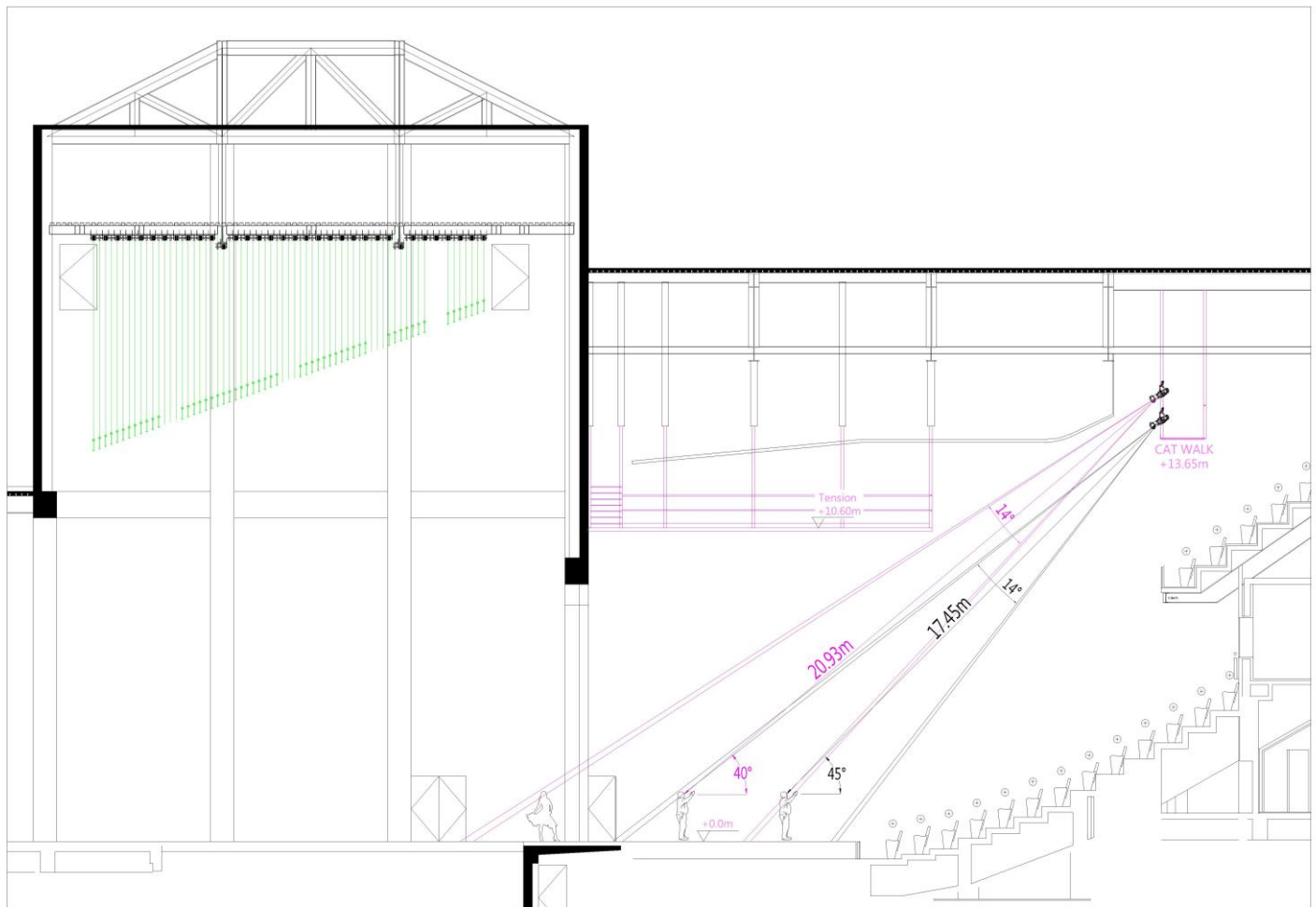

Figure 3.2.2- Lighting Section

3-3 Lighting DMX system

*Please patch all additional fixtures from (5)001,thanks.

Item	Position	Model	Quantity	Note	Paid Item
Node	Grid	MA3 4Port	2		
	DL Stage/DR Stage		1/1		
	UL Stage/UR Stage	MA3 2Port	1/1		
	Portable	MA2 2Port	5		
Isolator	Grid	Chauvet RDMX Splitter8	4	All isolators are 2 in 4 out (default)	

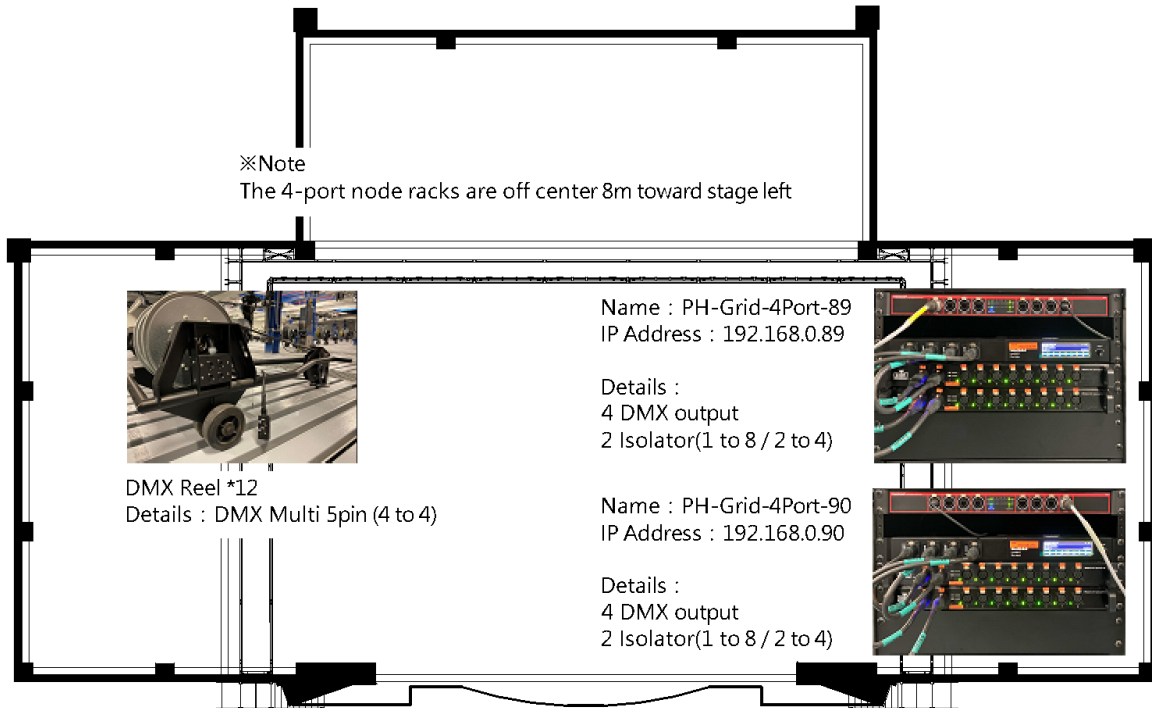

Figure 3.3.1- Grid Area Node Position Layout

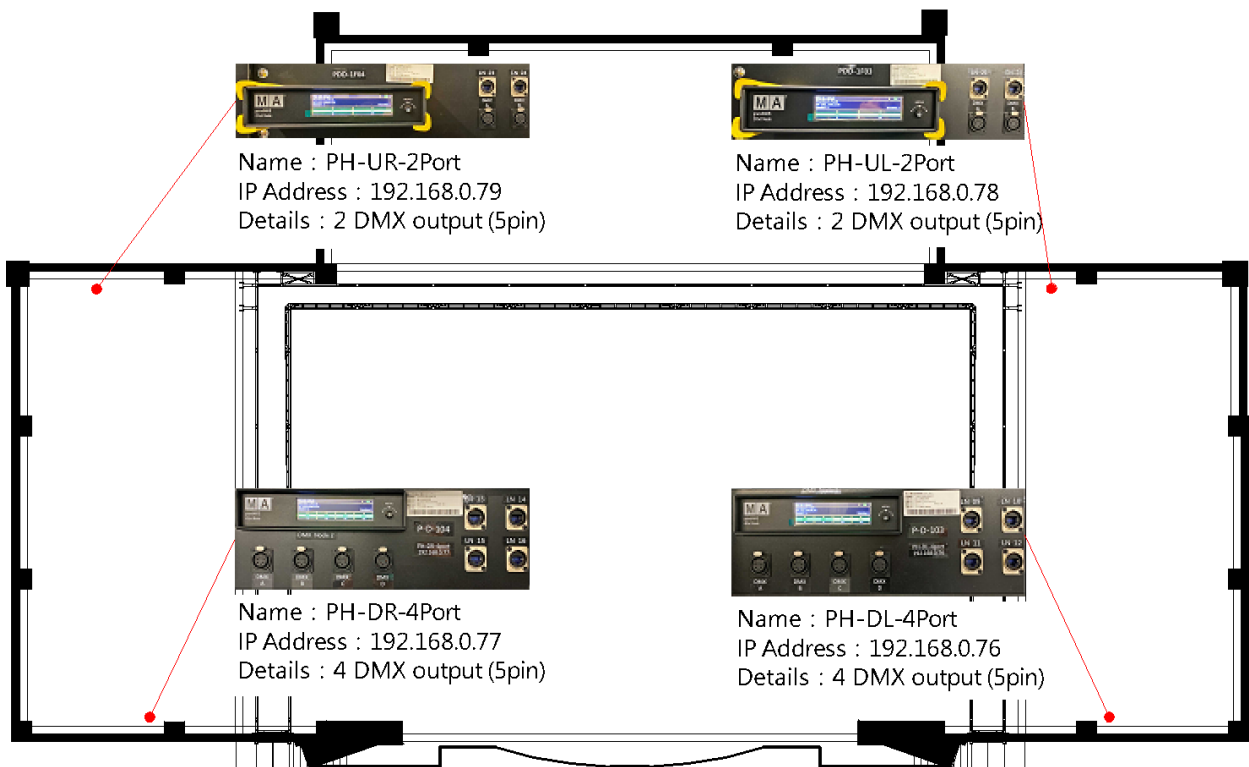

Figure 3.3.2- Stage Area Node Position Layout

3-4 Lighting Circuit

3-4-1 Stage area

Area and Position	Connector	Dimmer Circuit No.	Load	Network Circuit No.
Trap Room	CEE 16A	001 ~ 004	3kW	LN01 ~ 02
		005 ~ 008		
Orchestra Pit Lift	CEE 16A	479 ~ 482	3kW	LN03 ~ 04
		483 ~ 486		
Down Stage/L	Harting(8 circuits)	009 ~ 016 017 ~ 024	3kW	LN05 ~ 06
Down Stage/R	Harting(8 circuits)	025 ~ 032	3kW	LN07 ~ 08
		033 ~ 040		
Off Stage/L	Harting(8 circuits)	049 ~ 056	3kW	LN17 ~ 18
Off Stage/R	Harting(8 circuits)	065 ~ 072		LN19 ~ 20
Rear Stage/L	Harting(8 circuits)	073 ~ 080	3kW	
Up Stage/L	Harting(8 circuits)	041 ~ 048 081 ~ 088		
Rear Stage/R	Harting(8 circuits)	089 ~ 096	3kW	
Up Stage /R	Harting(8 circuits)	057 ~ 064 097 ~ 104		
Rear Stage	Harting(8 circuits)	105 ~ 112	3kW	LN25 ~ 26
		113 ~ 120		
Movable Tormentor Stage/L	CEE 16A (2 outputs/circuit)	121 ~ 124	3kW	
		125 ~ 128		
		129 ~ 132		
		133 ~ 136		
Movable Tormentor Stage/R	CEE 16A (2 outputs/circuit)	137 ~ 140 (137 is also use for circuit in Follow Room)	3kW	
		141 ~ 144 (144 is also use for circuit in Follow Room)		
		145 ~ 148		
		149 ~ 152		
Above Left Stage Rear Cable Reel	Harting(8 circuits)	153 ~ 160	3kW	
		161 ~ 168		
		169 ~ 176		
Gallery S.L	CEE 16A	177 ~ 180	3kW	LN55 ~ 56
		181 ~ 184		LN57 ~ 58
		185 ~ 188		
		189 ~ 192		
Gallery S.R	CEE 16A	193 ~ 196	3kW	LN59 ~ 60
		197 ~ 200		
		201 ~ 204		LN61 ~ 62
Gallery Rear Stage	CEE 16A	205 ~ 208	3kW	
		209 ~ 212		
		213 ~ 216		
		217 ~ 220		
Stage Grid Area	Harting(8 circuits)	221 ~ 224	3kW	LN63 ~ 64
		321 ~ 328		
		329 ~ 336		
		337 ~ 344		
		345 ~ 352		LN93 ~ 94
		353 ~ 360		LN95 ~ 96
		361 ~ 368		
		369 ~ 376		LN97 ~ 98
		377 ~ 384		
		385 ~ 392		LN99 ~ 100
		393 ~ 400		
		401 ~ 408		LN101 ~ 102
409 ~ 416				
417 ~ 424	LN103 ~ 104			
425 ~ 432				
433 ~ 440	LN105 ~ 106			
Down Stage/L	CEE 32A	443 ~ 446	5kW	

Down Stage/R	CEE 32A	449 ~ 452	5kW	
Up Stage/L	CEE 32A	453 ~ 456	5kW	
UP Stage/R	CEE 32A	461 ~ 464	5kW	
Gallery S.L.	CEE 32A	441 ~ 442	5kW	
		465 ~ 468	5kW	
Gallery S.R.	CEE 32A	447 ~ 448	5kW	
		457 ~ 460		
Rear Stage	CEE 32A	469 ~ 470	5kW	

Ca = CEE 16A
Cb = CEE 32A
H = Harting (8 Circuits)

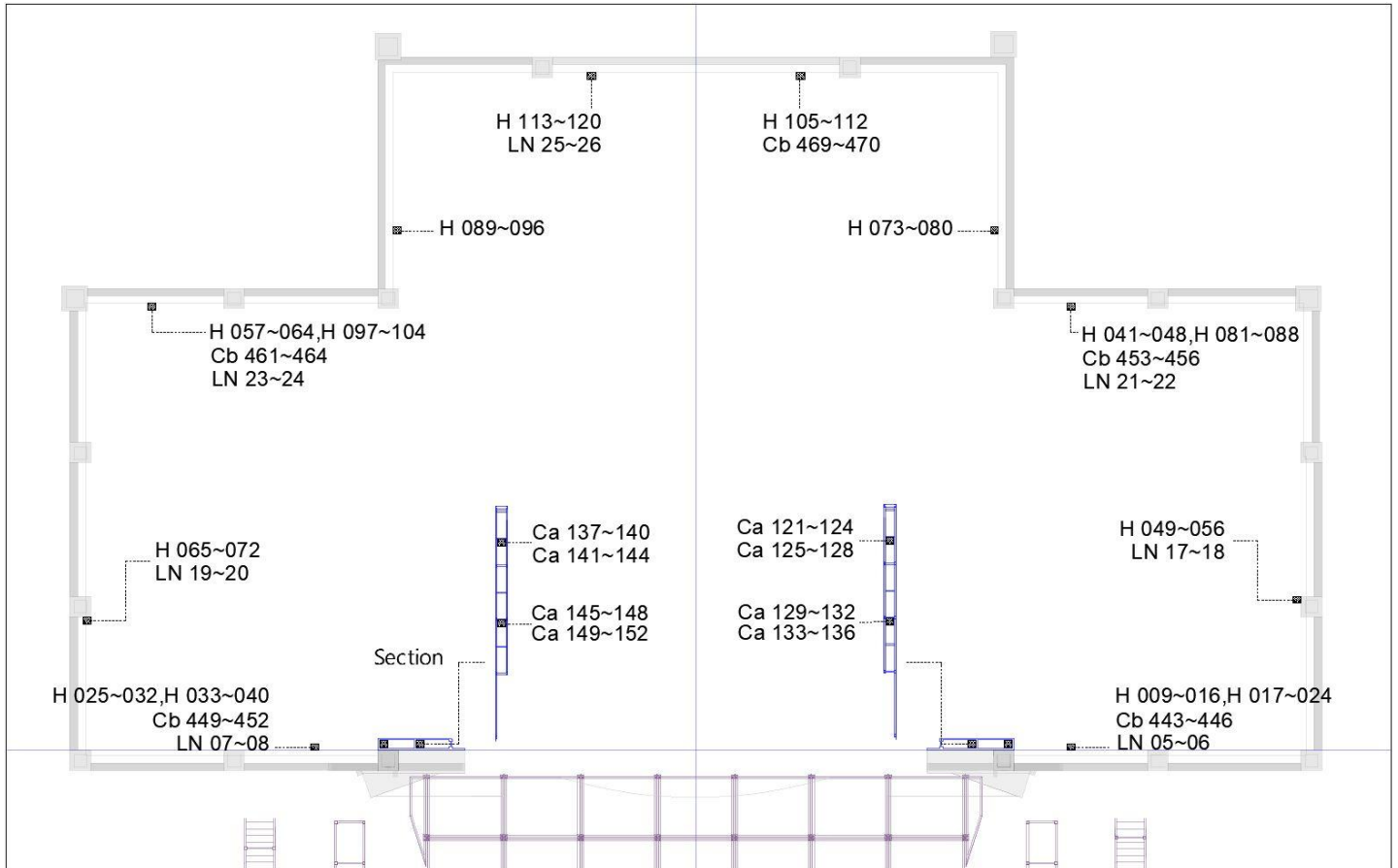

Figure 3.4.1.1- Stage Area Circuit Layout

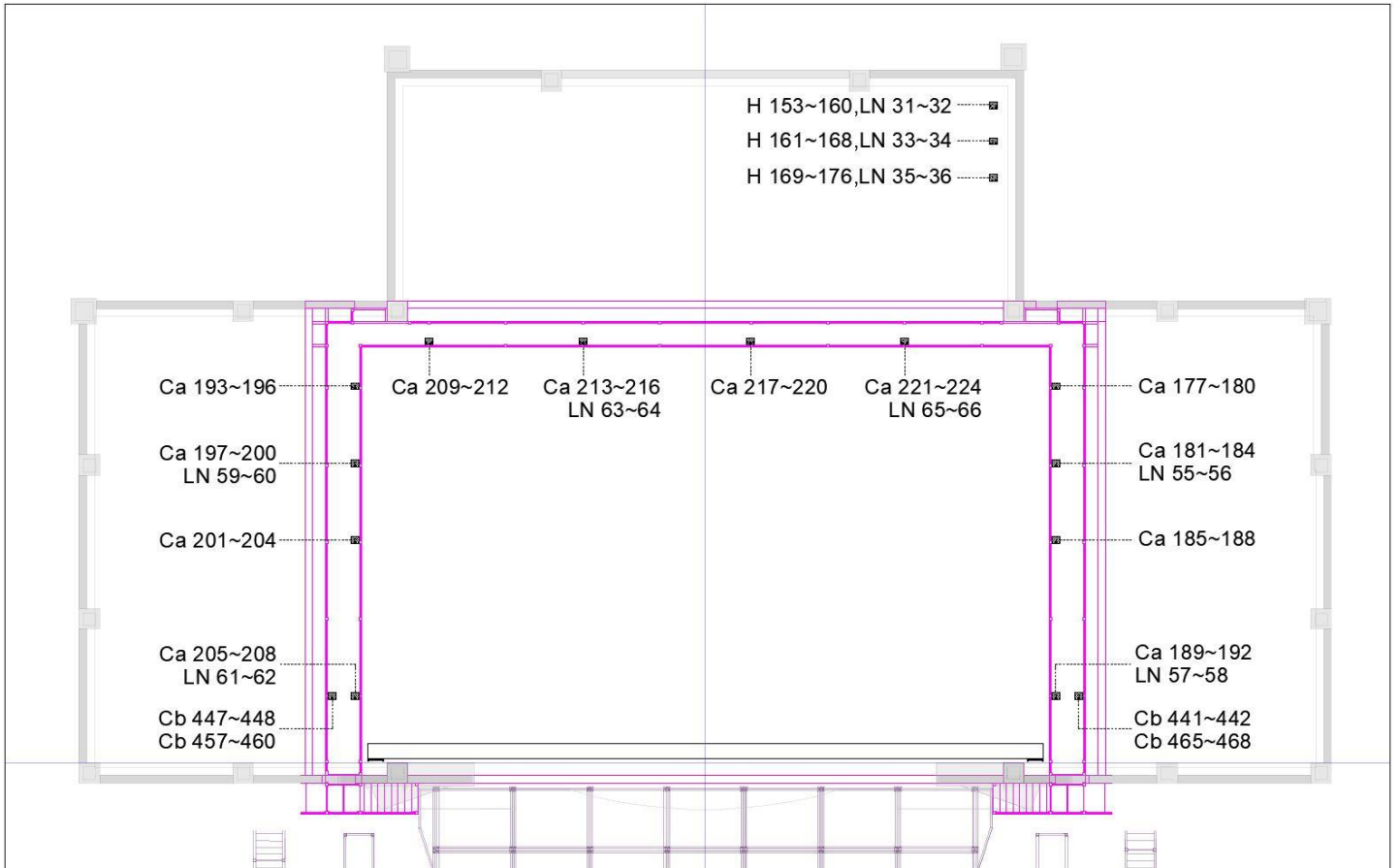

Figure 3.4.1.2- Gallery Circuit Layout

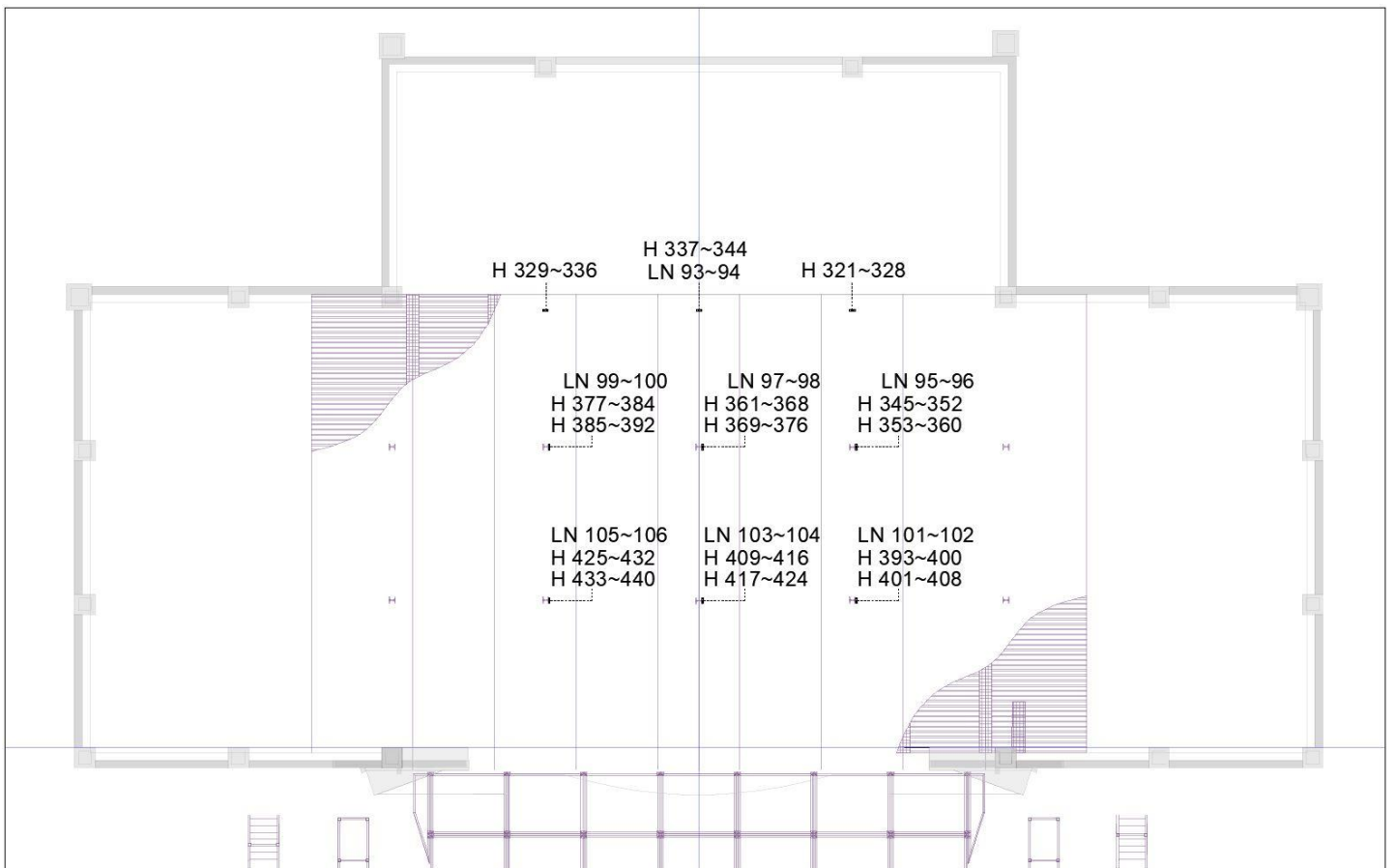

Figure 3.4.1.3- Grid Area Circuit Layout

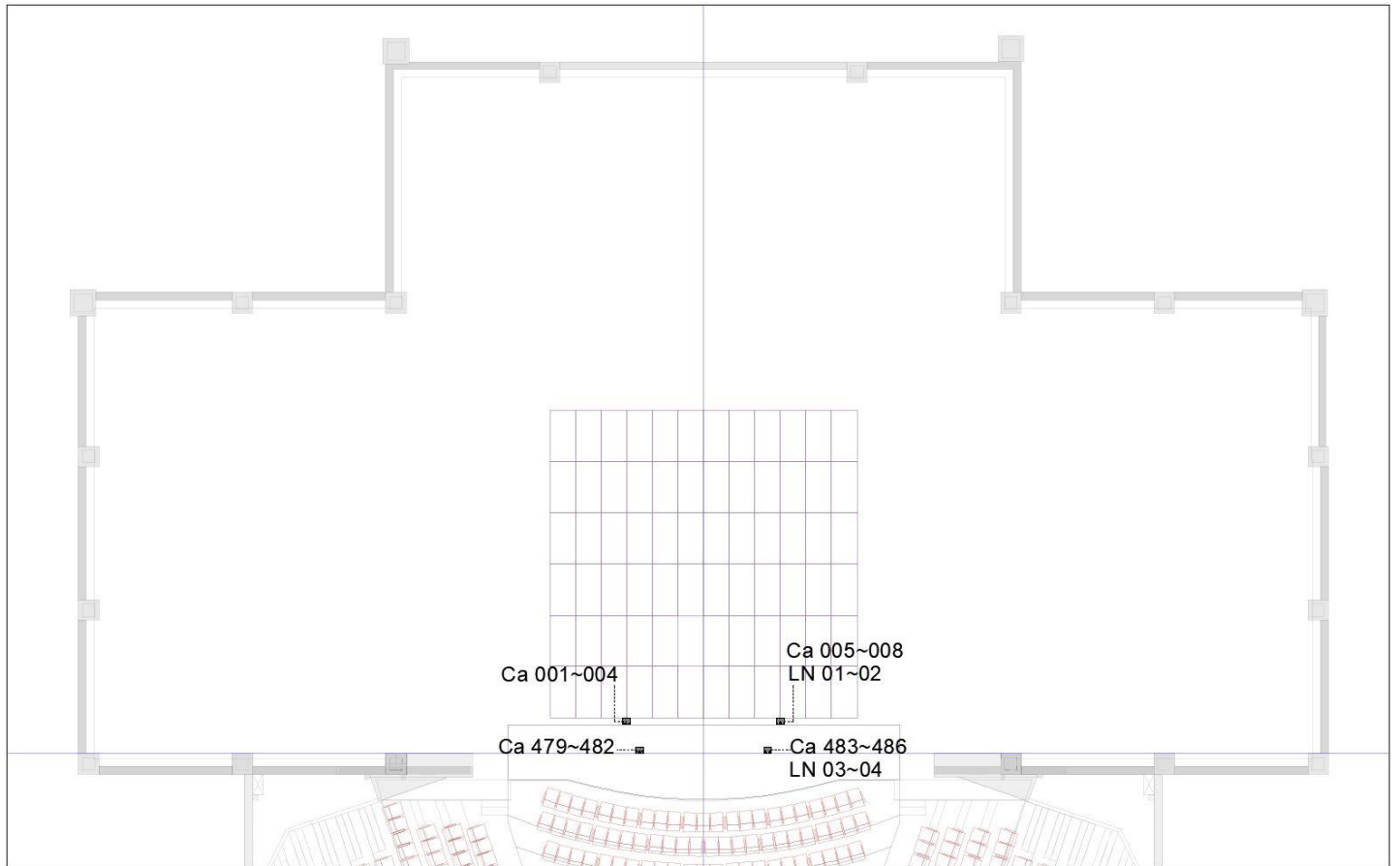

Figure 3.4.1.4- Stage Traps Room and Orchestra Pit Elevation Platform Circuit Layout

3-4-2 Front of House

Area and Position	Connector	Dimmer Circuit No.	Load	Network Circuit No.
Tension Grid	CEE 16A (2 outputs/circuit)	225 ~ 228	3kW	
		229 ~ 232		
		233 ~ 236		
		237 ~ 240		
		241 ~ 244		
		245 ~ 248		
		249 ~ 252		
		253 ~ 256		
		257 ~ 260		
		261 ~ 264		
Tension Grid	Harting(8 circuits)	273 ~ 280	3kW	LN71 ~ 72
		281 ~ 288		LN73 ~ 74
		289 ~ 296		LN75 ~ 76
		297 ~ 304		LN77 ~ 78
		305 ~ 312		LN79 ~ 80
		313 ~ 320		LN81 ~ 82
Auditorium Aisle	CEE 16A	471 ~ 474	3kW	LN37 ~ 38
		475 ~ 478		LN39 ~ 40
Balcony Rail S.R.	CEE 16A	487 ~ 489	3kW	LN67 ~ 68
		490 ~ 492		
		493 ~ 495		
		496 ~ 498		
		499 ~ 501		
		502 ~ 504		
		505 ~ 507		
Balcony Rail S.L.	CEE 16A	511 ~ 513	3kW	LN69 ~ 70
		514 ~ 516		
		517 ~ 519		
		520 ~ 522		
		523 ~ 525		
		526 ~ 528		
		529 ~ 531		
		532 ~ 534		
Follow Room	CEE 16A	137 (137 is also use for circuit in Movable Tormentor Stage/R)	3kW	LN3063B-1
		144 (144 is also use for circuit in Movable Tormentor Stage/R)		LN3063B-2
Catwalk	CEE 16A (2 outputs/circuit)	535 ~ 538	3kW	LN83 ~ 84 LN85 ~ 86 LN87 ~ 88
		539 ~ 542		
		543 ~ 546		
		547 ~ 550		
		551 ~ 554		
		555 ~ 558		
		559 ~ 562		
563 ~ 566				

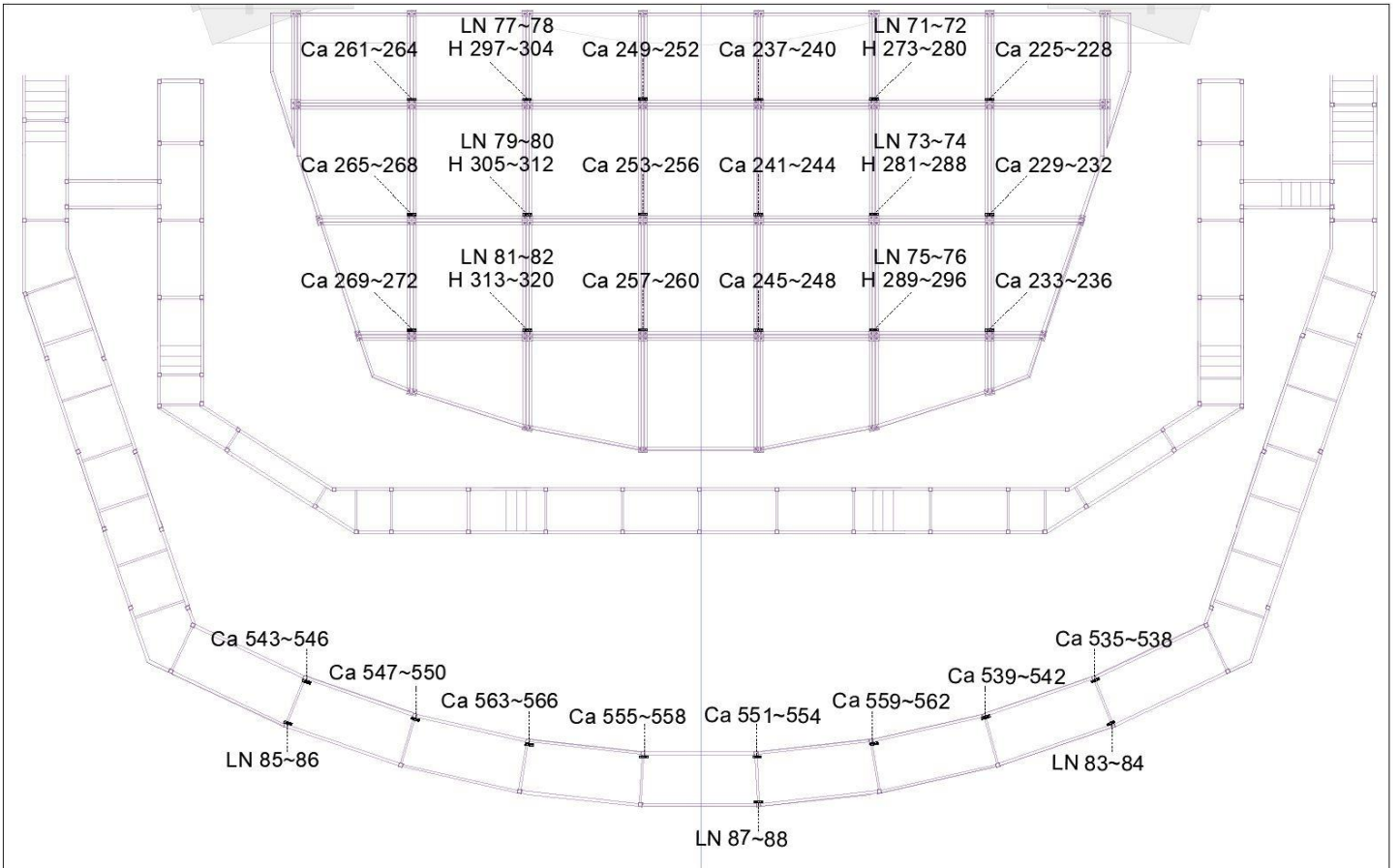

Figure 3.4.2.1- Tension Grid and Catwalk Circuit Layout

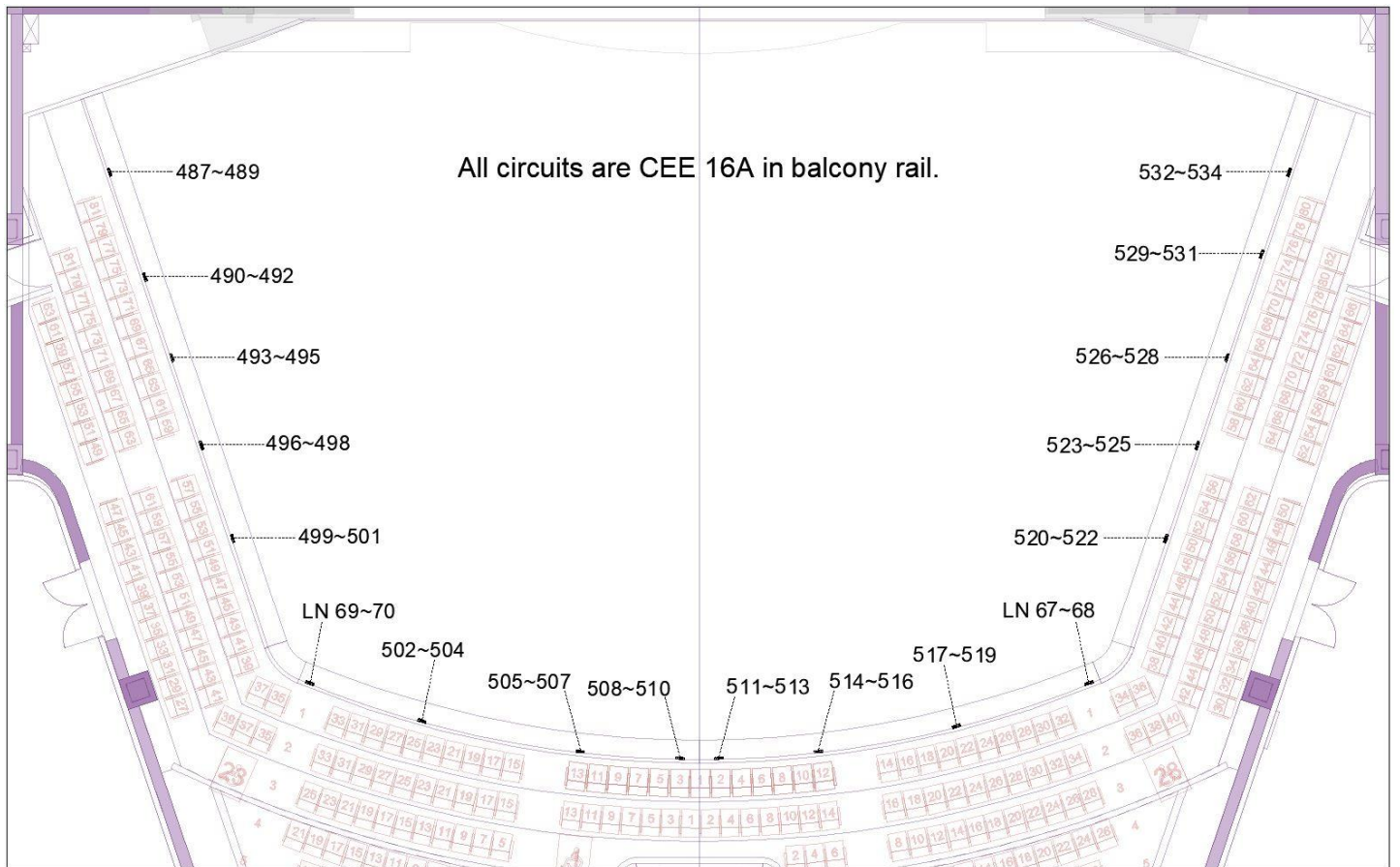

Figure 3.4.2.2- Balcony Rail Circuit Layout

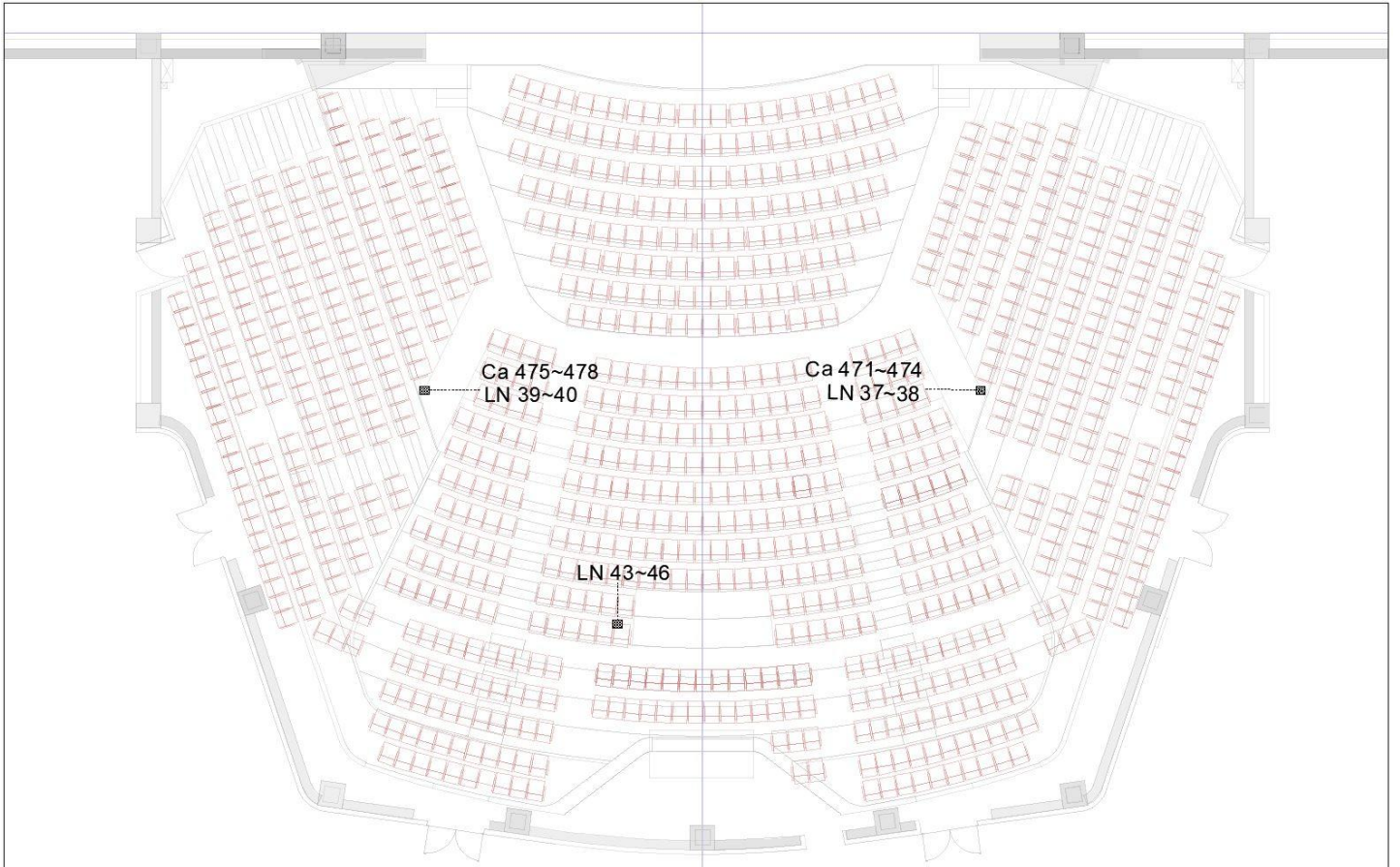

Figure 3.4.2.3- Auditorium Circuit Layout

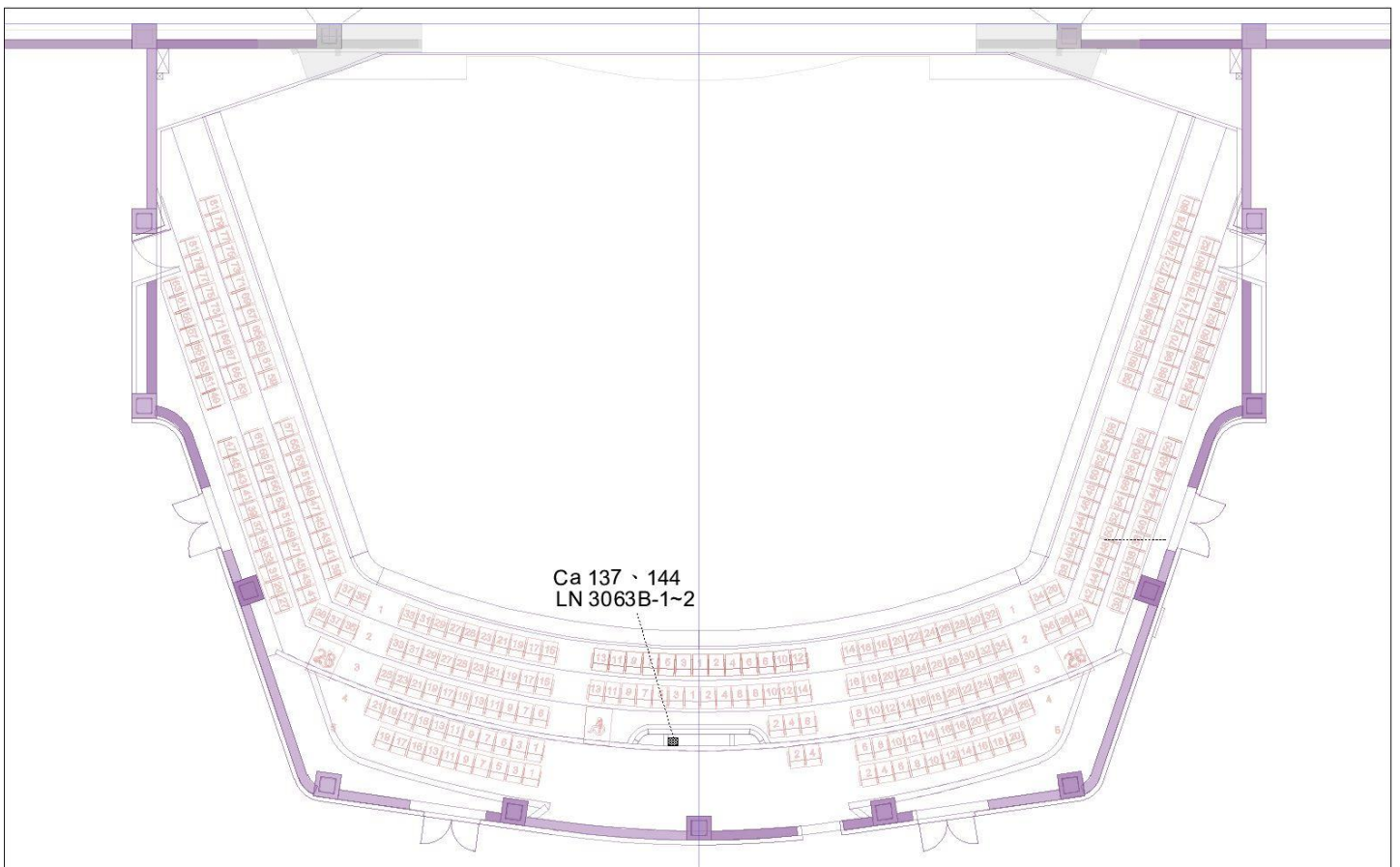

Figure 3.4.2.4- Follow Room Circuit Layout

3-5 Portable Lift

Brand and Model : Snorkel UL-40 (Battery Power Supply)
 Maximum height: 12.1m
 Maximum weight: 136kg
 Quantity: 1

3-6 Additional Power Supply

Function	Position	Specifications	Quantity
Stage	Down Stage Left / Right	3φ4W+G 380V/220V /60Hz (CEE 125A/3P+N+PE)	1 / 1
Light		3φ4W+G 208V/120V /60Hz (Camlock 250A)	1 / 1
Sound		3φ4W+G 208V/120V /60Hz (Camlock 100A)	1 / 1
Stage		3φ4W+G 380V/220V /60Hz (CEE 125A/3P+N+PE)	2 / 2 1 / 1 / 2 1 / 1

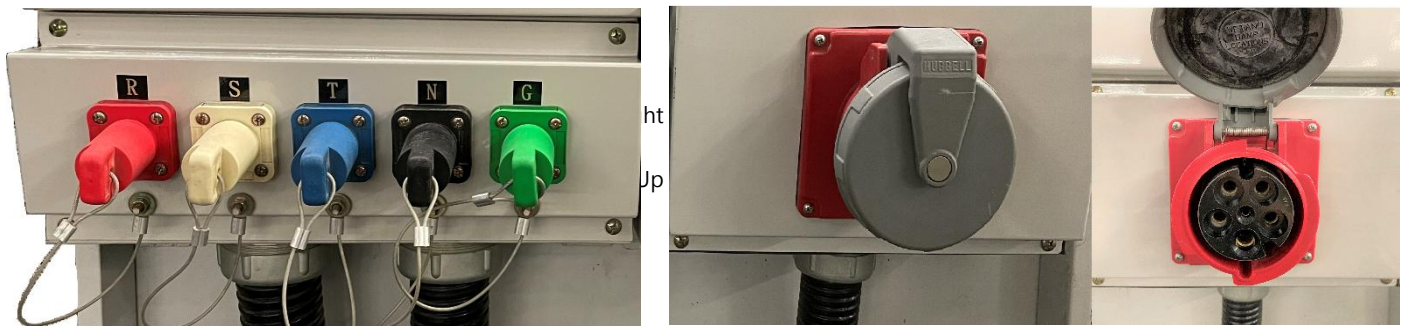

Light		3φ4W+G 208V/120V /60Hz (Camlock 250A)	2 / 2 1 / 1 / 2 1 / 1
Projector	Rear Stage(Right)	220V/60Hz (CEE 32A)	1

Figure 3.6- Additional Power Supply

3-7 Working Light / House Light

Work lights

Work lights provided white and blue light mode, and the control switch is located on the stage manager' s Desk.
 Lighting area: Stage, stage Traps room, under Elevation Platform (include machine pit), Orchestra Pit, Gallery, Tension Grid, Stage Grid area, Cat walk and seat storage room.

Auditorium lights

Auditorium lights consists houselights and step lights, which can be separately controlled and dimmed. The control panel is located on the stage manager' s Desk and lighting control room.

4 Audio/Video-Systems

4-1 Audio Facilities

Item	Quantity	Brand and Model	Paid Item
Main speaker(Left and right channels)	4	Renkus-Heinz STX2/64	
Main speaker (Center channel)	3	Renkus-Heinz STX2/64	
Left and right channel auxiliary speaker	2	Renkus-Heinz STX2/94	
3F Auditorium auxiliary speaker (Center)	4	Renkus-Heinz STX2/94	
3F Auditorium auxiliary speaker (Left and right)	4	Renkus-Heinz CA/CX121	
Subwoofer	4	Renkus-Heinz BPS15-2K	
Surround speakers	16	Renkus-Heinz PNX81/12	
Stage front speakers	12	Renkus-Heinz CFX 41	
12" Stage Active speaker	2	Renkus-Heinz PN121/9	
15" Stage Active speaker	2	Renkus-Heinz PN151/9	
Digital I/O Fiber Module	2	Studer D21M	
Follow RM. speakers	2	Dynaudio BM compact MkIII	
Movable auxiliary speaker	2	Renkus-Heinz PNX151T/9A Renkus-Heinz DRS18-1B LabGruppen PLM10000Q	
Stereo audio converter	1	Whirlwind PcUSB 2-Channel USB Direct Box	
Digital Mixer	1	Soundcraft Vi4	*
12" Stage Active speaker	8	Renkus-Heinz PN121M/12	*
6.5" Stage Active speaker	6	Renkus-Heinz PN61	*
Dual channel Equalizer	4	BSS FCS 960	*
Mixing console	1	Midas M32R LIVE Stage Box : Midas DL16 Comes with RJ-45 cable	* (Shared with four halls)
Wireless PA equipment MIPRO MA-708	4	MIPRO MA-708 (Recommended for indoor use)	* (Shared with four halls)
Wireless PA equipment MIPRO MA-808	2	MIPRO MA-808	* (Shared with four halls)
Wireless PA equipment MIPRO MA-828	2	MIPRO MA-828	* (Shared with four halls)
Mixing console Comb	3	Mixer : YAMAHA DM3 Standard Handheld Wireless Microphone : Mipro ACT-747 x 1 、 ACT-700H x 4 Speaker : Renkus-Heinz PN61 x 2 Including assembly and disassembly and execution manpower.	* (Shared with four halls)
Mixing console	1	Midas heritage D HD96-24-CC-TP Stage Box : Midas DL231	* (Shared with four halls)
Signal Splitters	1	Midas DL431	* (Shared with four halls)

Items with * mark are paid items. Please refer to the rate tables of National Kaohsiung Center for the Arts.

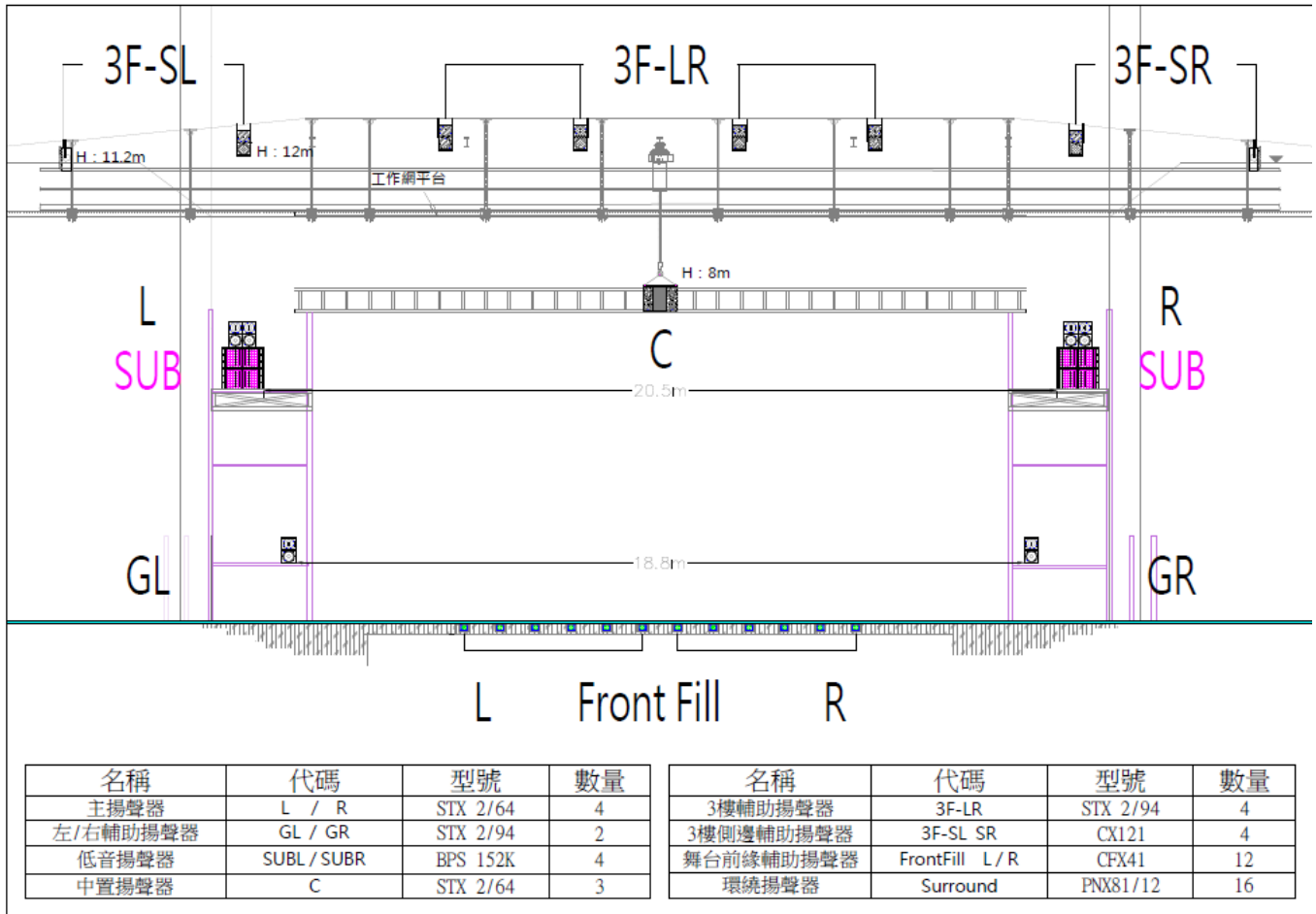

Figure 4-1.1 Speaker elevation diagram

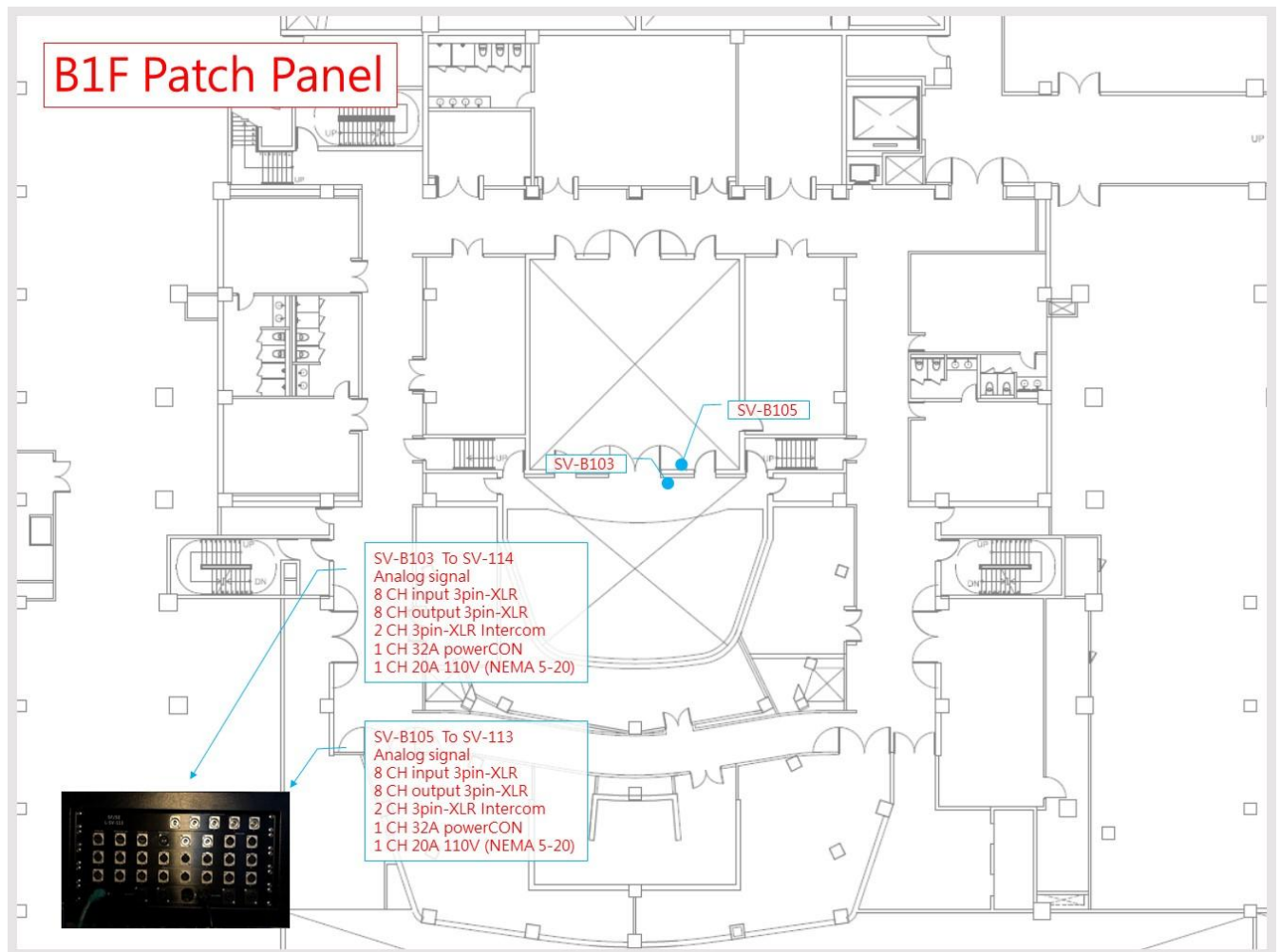

Figure 4-1.2 B1F Audio system channel diagram

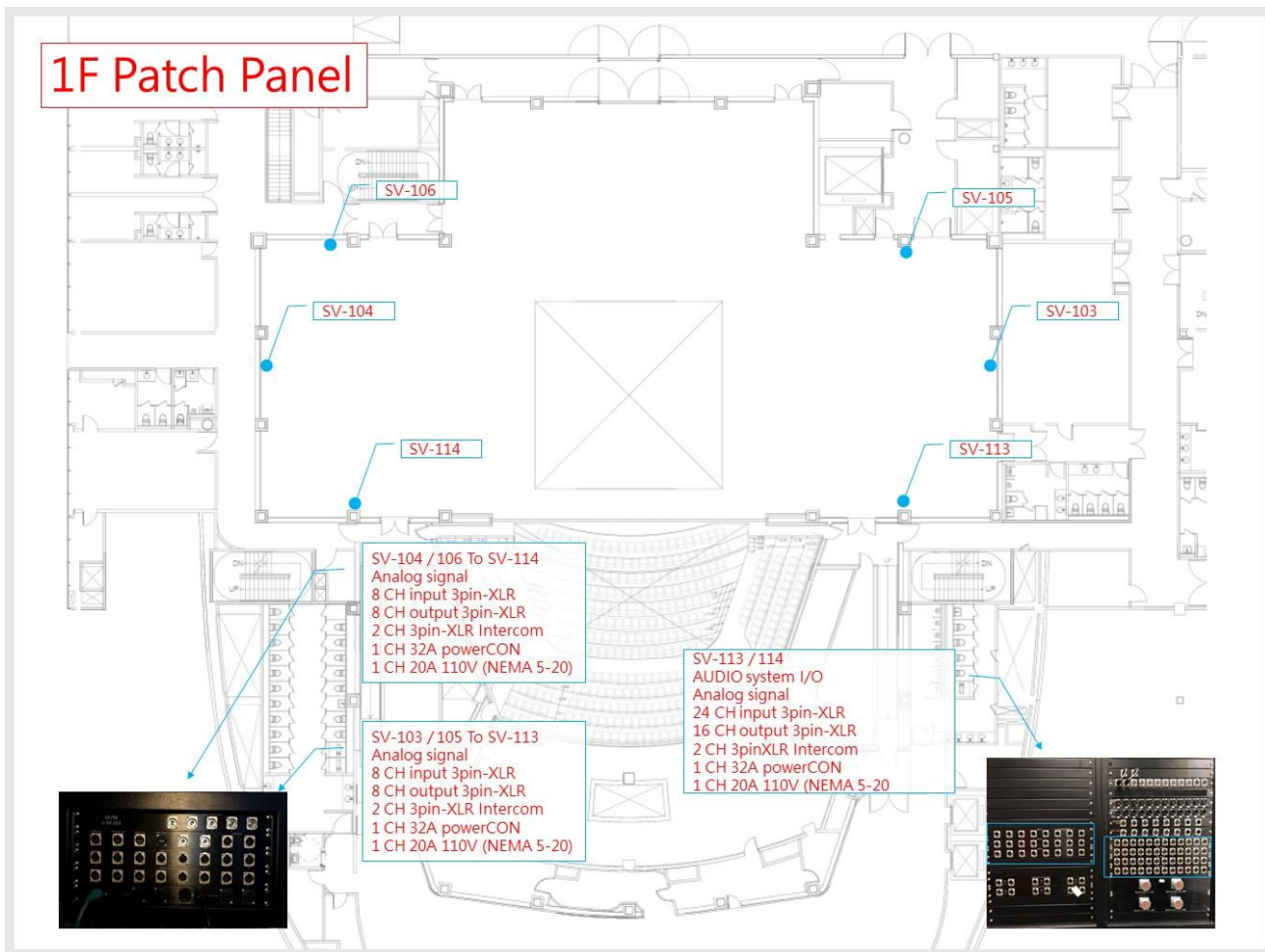

Figure 4-1.3 1F Audio system channel diagram

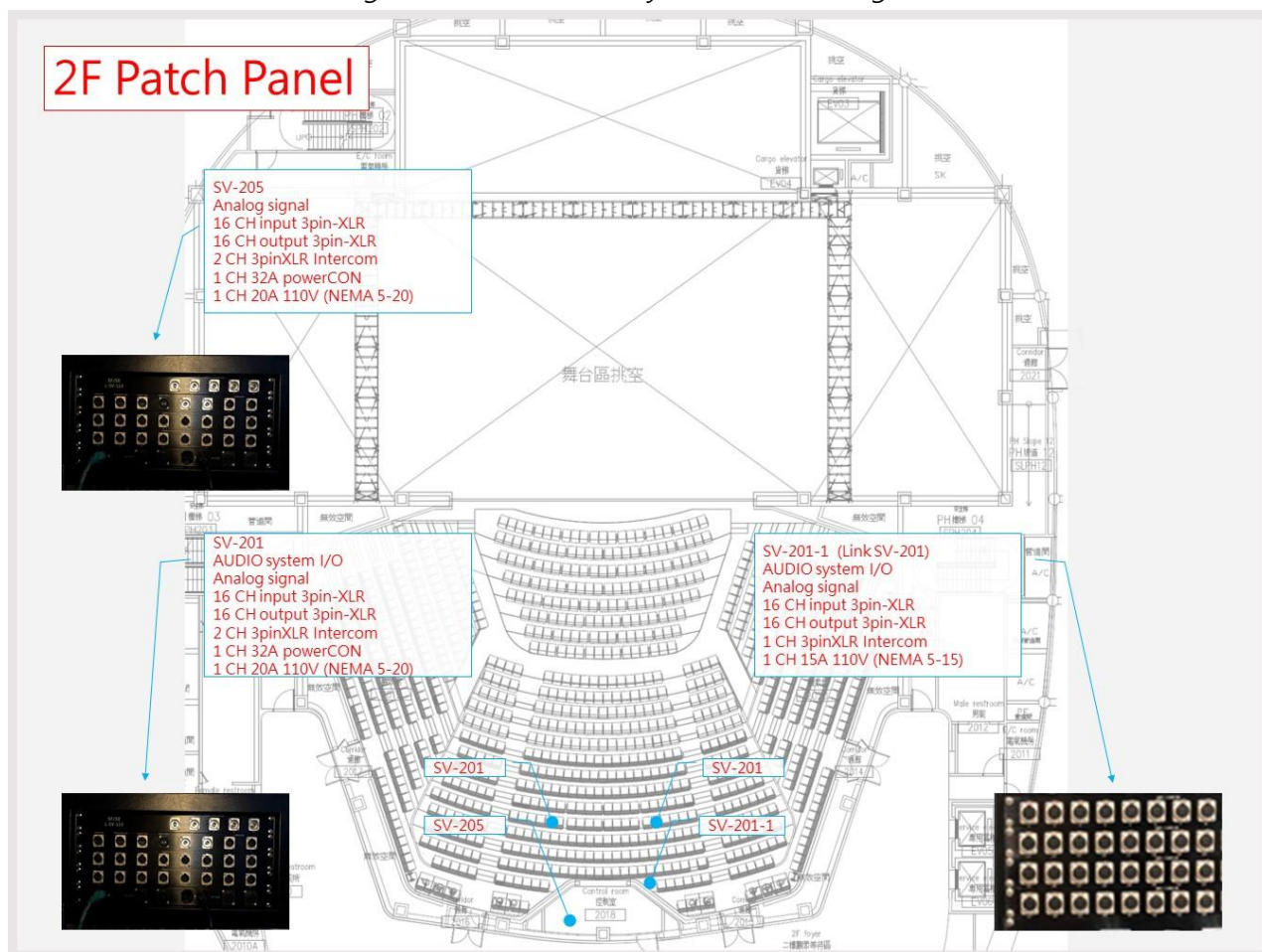

Figure 4-1.4 2F Audio system channel diagram

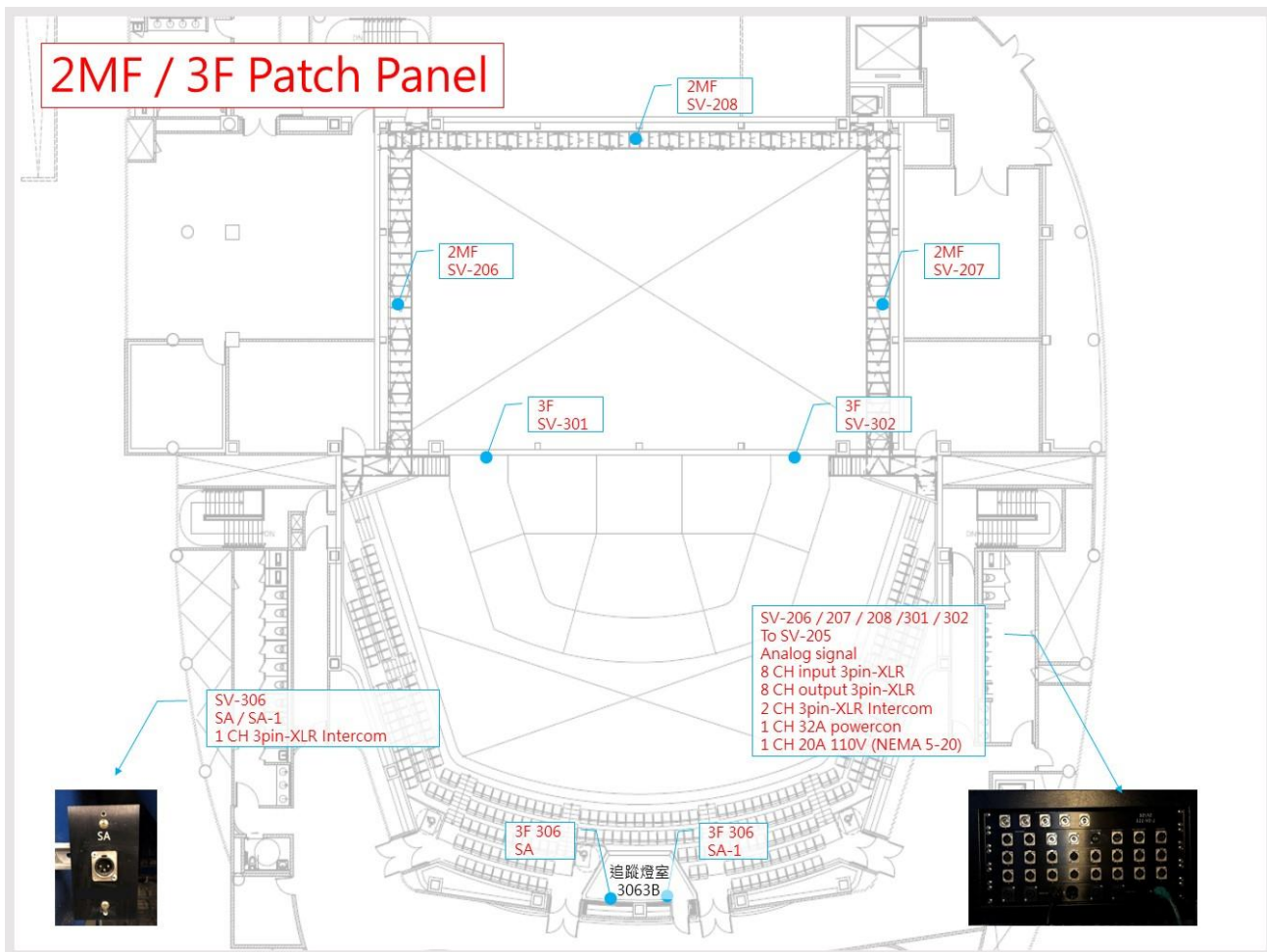

Figure 4-1.5 2MF / 3F Audio system channel diagram

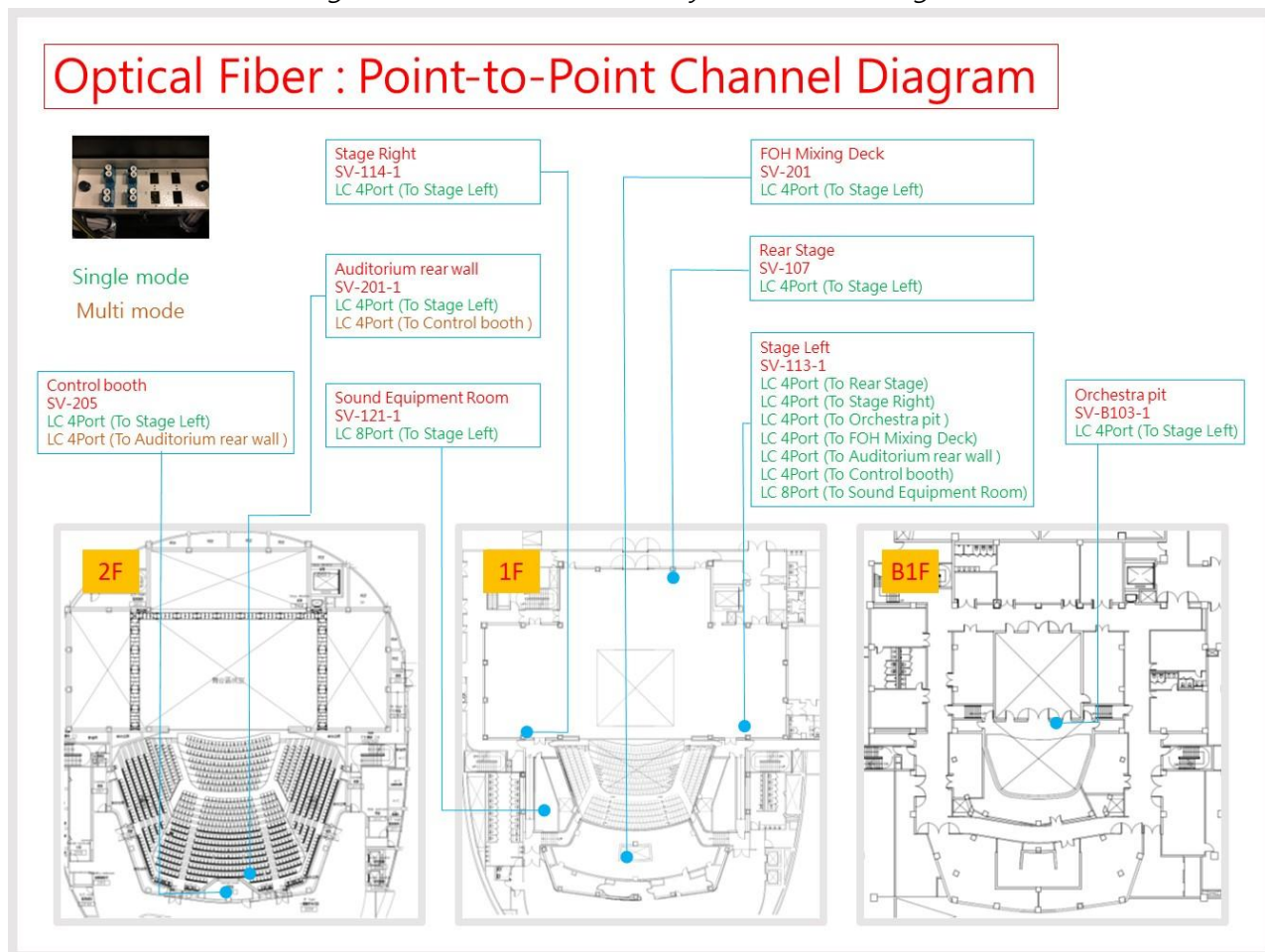

Figure 4-1.6 Optical fiber point-to-point channel diagram

Point-to-Point Channel Diagram

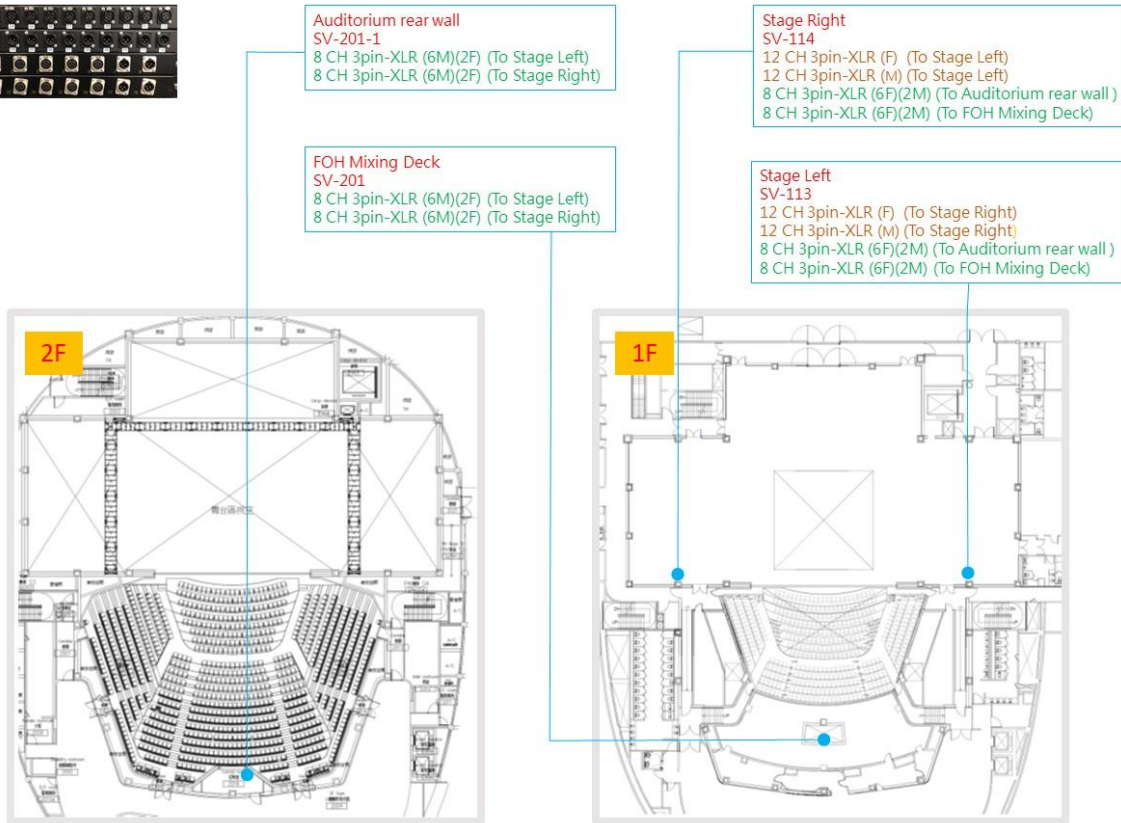

Figure 4-1.7 Signal point-to-point channel diagram

RJ45 : Point-to-Point Channel Diagram

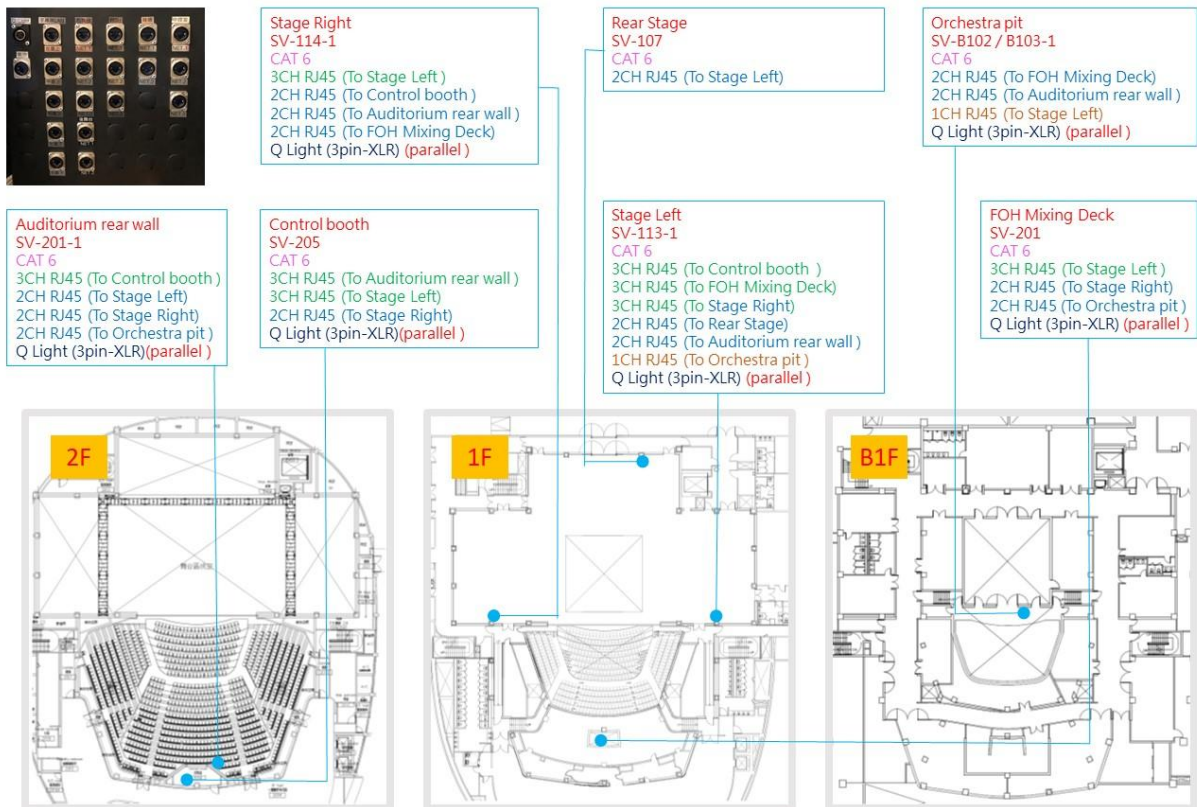

Figure 4-1.8 RJ45 point-to-point channel diagram

4-2 Control Room

Item	Quantity	Brand and Model	Paid Item
Master Digital Mixer (Control Room standard configuration)	1	Studer Vista 5 M3 QS	
Digital I/O Fiber Module	1	Studer D21m	
CD Player	1	Tascam CD-500B	*
CD-R Player	1	Tascam CD-RW 901 MKII	*
Dual channel Digital Effects	2	Eventide Eclipse V4	
Multitrack Recording equipment	1	JoeCo BBR1D+2.5" USB 1TB HD	*
Dual track Hard disk recorder	1	Tascam DA 3000	*
Active speaker	2	Dynaudio BM12 MkIII	

Items with * mark are paid items. Please refer to the rate tables of National Kaohsiung Center for the Arts.

4-3 Stage Manager's Console

The stage manager desk equips with a live sound monitor, video monitors, synchronous show screens with lighting and fly, communication system and paging system.

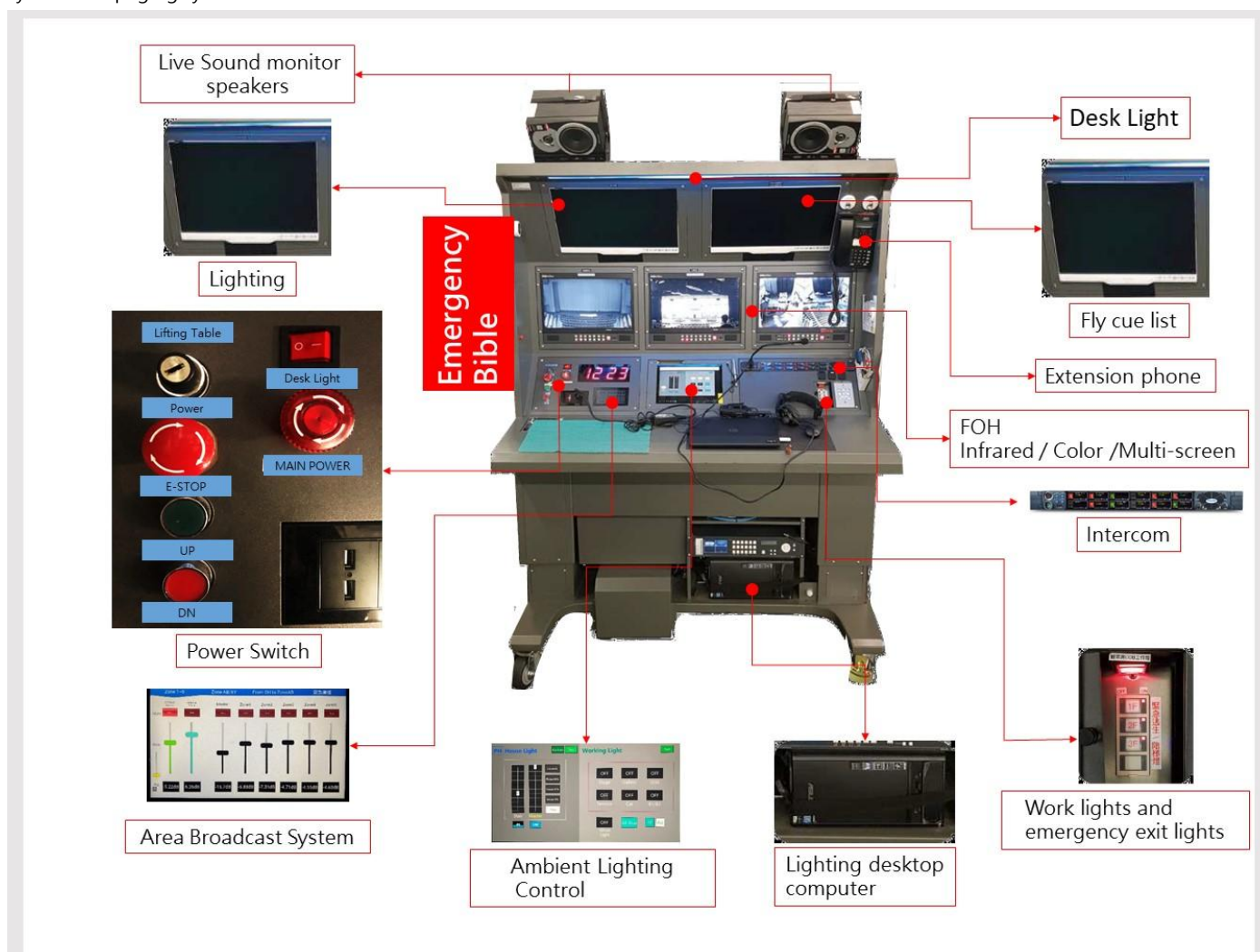

Figure 4-3.1- Stage Manager Desk

4-4 Microphone

Item	Quantity	Brand and Model	Paid Item
Single channel wireless microphone receiver	16	Sennheiser EW500G3	
Wireless microphone wave antenna	2	Sennheiser AD3700	
Wave antenna distributor	3	Sennheiser ASA1	
Stage reception Microphone	2	DPA 4017B / DPA UA 0836 Holders	
Dynamic microphone Audio Technica AE4100	4	Audio Technica AE4100	*
Dynamic microphone Audio Technica ATM250	8	Audio Technica ATM250	*
Condenser microphone	4	Audio Technica AE5400	*
Cardioid Condenser microphone	6	Audio Technica AT4021	*
Gradient Condenser microphone	4	Audio Technica BP4073	*
Cardioid Condenser Boundary Microphone	4	Audio Technica U851R	*
Hypercardioid Condenser microphone	6	AKG CK63-ULS+C480B	*
Cardioid condenser microphone	6	AKG CK61-ULS+C480B	*
Wireless microphone	4	Sennheiser SKM500G3+MME865	*
Mini wireless microphone	12	Sennheiser SK500G3+MKE2	*
Condenser microphone Neumann U87 Ai Studio Set	1	Neumann U87 Ai Studio Set Accessories : EA 87 / WS 87	*
Condenser microphone Neumann KM184	8	Neumann KM184 Accessories : SG 21 bk / WNS 100	*
Condenser microphone DPA 2011C/MMP-C	4	DPA 2011C/MMP-C	*
Condenser microphone DPA 4099-DC-1(For Loud SPL)/DAD6001-BC	8	DPA 4099-DC-1(For Loud SPL)/DAD6001-BC 9 Types of accessories: 1.DoubleBass(BC4099) x 2 2.Cello(CC4099) x 2 3.Piano(PC4099) x 2 4.Clamp(CM4099) x 2 5.Guitar(GC4099) x 4 6.Sax and Trumpet(STC4099) x 2 7.MIC Stand(MS4099) x 1 8.Microphone Clip(UC4099) x 2 9.Violin and Mandolin(VC4099) x 8	*

Items with * mark are paid items. Please refer to the rate tables of National Kaohsiung Center for the Arts.

4-5 Communications

Item	Quantity	Brand and Model	Paid Item
Intercom host machine (Matrix 32 x 32)	1	Clear-Com Eclipse HX-Delta	
System interface	1	Clear-Com Helixnet HMS-4X	
Double circuit intercom	8	Clear-Com Helixnet HBP-2X	
Fixed intercom microphone/ speak	2	Clear-Com V12PDXY 110 / 340 Clear-Com V12PDDXY 110 / 340	
Single head receiver microphone	8	Clear-Com CC-300	
Double head receiver microphone	4	Clear-Com CC-400	
Telephone intercom	2	Clear-Com HS-6	
Digital Wireless Intercom set	8	1. Portable wireless sub-station / Clear-Com FSII-BP 2. Single-ear headset / Clear-Com CC-300	*

Items with * mark are paid items. Please refer to the rate tables of National Kaohsiung Center for the Arts.

4-6 Locations of Communications

Each floor is paired with intercom system, 34 units in total.

No.	Floor	Location
1	B1F	Orchestra area
2		Orchestra area
3		Orchestra area
4		Stage trap area
5		Rest room
6	1F	Stage left
7		Stage right
8		Upstage left
9		Upstage right
10		Rear stage
11		Stage left proscenium
12		Stage right proscenium
13		Loading Dock
14		Left downstage
15		Right downstage
16		Dressing room 01
17		Dressing room 02
18		Dressing room 03
19		Dressing room 04
20		Sound room
21	2F	Auditorium control area
22		Control room
23		Control room
24	2MF	Stage right work corridor
25		Stage left work corridor
26		Rear stage work corridor
27		Floor leading edge
28	3F	Right tension
29		Left tension
30		Dimmer room
31		Amplifier room
32	4F	Follow room
33		Winch room
34		Catwalk

4-7 Stage Cameras and Video Surveillance Systems

Stage monitors are installed in right and left stage entrances, first, second, and third floor lobbies, master and secondary control rooms, dressing rooms and green rooms.

Item	Quantity	Brand and Model	Paid Item
Camera	1	SONY ILME-FR7	
Camera console	1	Panasonic AW-RP120	
Infrared camera	1	AIDA GEN3G-200	
Video recording	Show	Fixed camera for stage panoramic view recording, only suitable for archived copy.	

Items with * mark are paid items. Please refer to the rate tables of National Kaohsiung Center for the Arts.

4-8 Paging Systems

Backstage Paging Systems available for all dressing rooms, green rooms, Company office and Corridors, see next page. The Paging and Program position is located on the Stage Manager Desk.

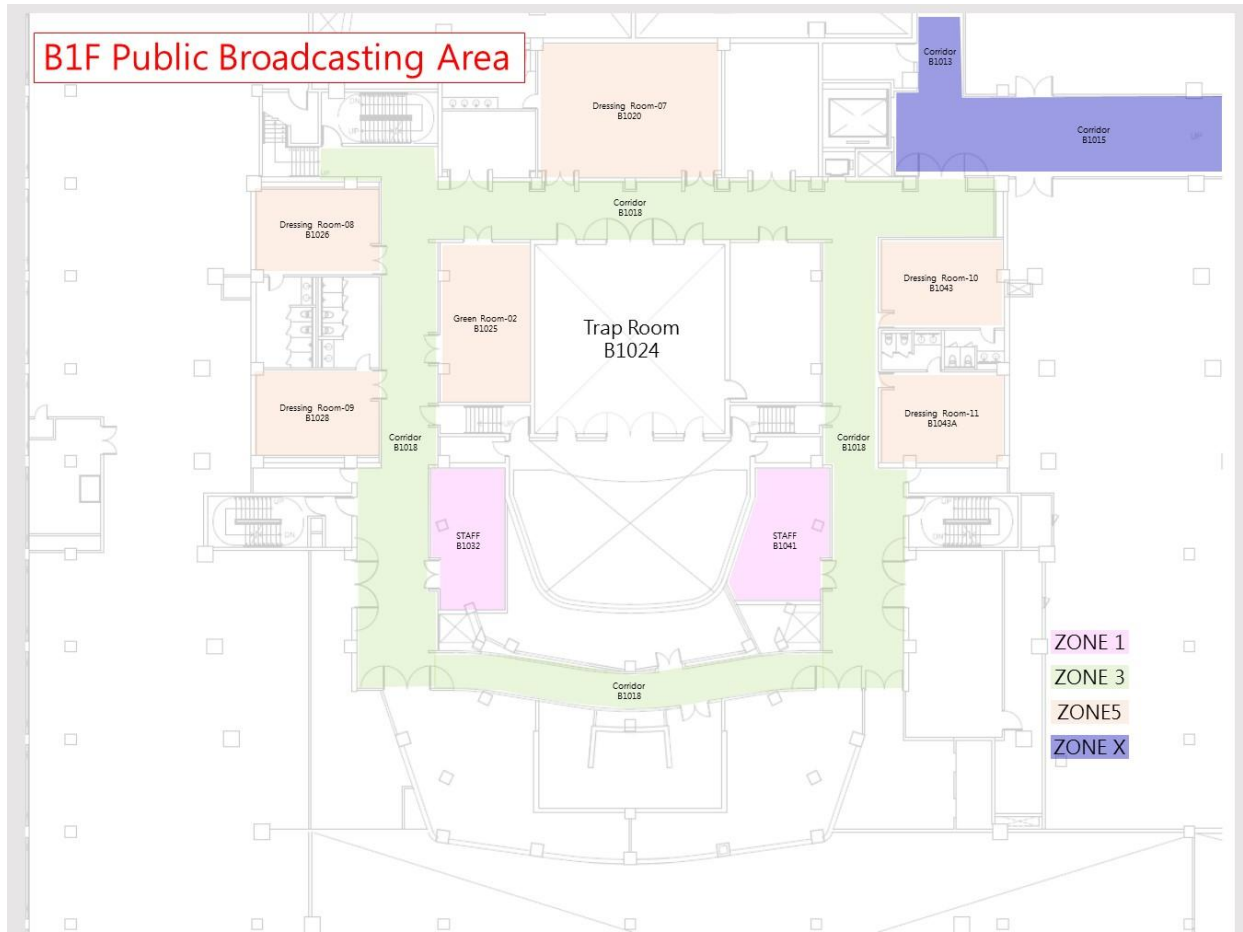

Figure 4-8.1 B1F public broadcasting area icon

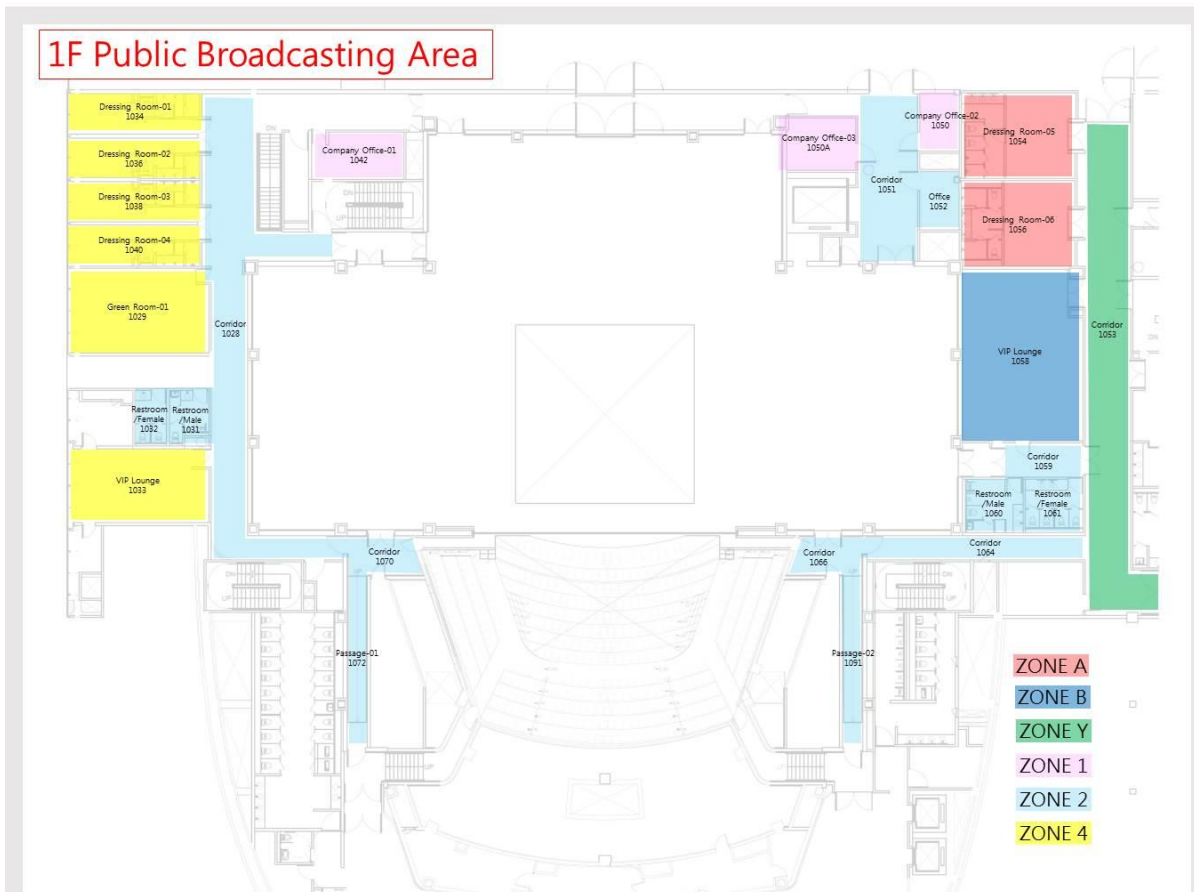

Figure 4-8.2 1F public broadcasting area icon

4-9 Projector

Item	Quantity	Brand and Model	Paid Item
20k Lumens Projector	2	Digital Projection Titan Super Quad 1080p 3 Choices of lens: 1. Wide-angle lens (Fixed) (Throw ratio 0.67 : 1) 2. Normal lens (Zoom)(Throw ratio 1.87~2.56 : 1) 3. Telephoto lens(Zoom) (Throw ratio 2.56~4.16 : 1)	* Option 2
5K Lumens LCD Projector	2	NEC PE501XG Including assembly and disassembly manpower, excluding execution manpower.	* (Shared with four halls) Option 1
5K Lumens Laser Projector	2	Optoma ZU500USTe Projection distance (45.7cm 132 inches - 58.3cm 155 inches)	* (Shared with four halls) Option 2
6K Lumens Laser Projector	2	Panasonic PT-VMZ60T · Wide-angle lens(Zoom) Lens : throw ratio 1.09 -1.77 : 1	* (Shared with four halls) Option 2
10K Lumens Laser Projector	1	Panasonic PT-RCQ10 · Normal lens (Zoom) Lens : throw ratio 1.71~2.41 : 1	* (Shared with four halls) Option 2
Dedicated Ultra Short Focus Lens	1	ET-DLE020 · Lens : throw ratio 0.28~0.299 : 1 (For Panasonic PT-RCQ10)	* (Shared with four halls) Option 2
30K Lumens Laser Projector	2	Panasonic PT-RQ35K with 3 choices of lens: 1. Panasonic ET-D3LEW60 (Throw ratio 0.991-1.18:1) 2. Panasonic ET-D3LEW10 (Throw ratio 1.35-1.84:1) 3. Panasonic ET-D3LES20 (Throw ratio 1.79-2.59:1)	* (Shared with four halls) Option 2 · 3
17.3" FULL HD LCD Monitor	2	Datavideo TLM-170L	* (Shared with four halls) Option 1
Projection screen	4	Grandview X-Press Pull-UP 100-inch projection screen(W203cm*H152cm)	* (Shared with four halls) Option 1

Items with * mark are paid items. Please refer to the rate tables of National Kaohsiung Center for the Arts.

Option 1 : Setup and operating is not included !

Option 2 : Operating is not included !

Option 3 : Rental fee 50% off from second show.

4-10 Subtitle

Item	Quantity	Brand and Model	Paid Item
LCD Subtitle display screen(Combo A)	1 set	1. 12 Panasonic (TH-55LFV70W) (W121.3 x H68.4 x D9.5 cm) 2. 2 Laptop 3. 1 Switcher	* Option 1
LED Subtitle display screen(Combo B)	1 set	1. P2.604mm LED display 750*100cm (1 cord) 、 250*150cm (2 cord) 2. 2 Laptop 3. 1 Switcher	* Option 1
LED Subtitle display screen(Combo C)	1 set	1. P2.604mm LED display 250*150cm (2 cord) 2. 2 Laptop 3. 1 Switcher	* Option 1
LED Subtitle display screen(Combo D)	1 set	1. P2.604mm LED display 750*100cm (1 cord) 2. 2 Laptop 3. 1 Switcher	* Option 1

** Items with * mark are paid items. Please refer to the rate tables of National Kaohsiung Center for the Arts.*

Option 1 : Operating is not included ! Rental fee 50% off from second show. Only for Opera House or Playhouse.

5 Backstage

5-1 Dressing Room and Green Room · Company office

No.	Floor	Room No.	Name	Capacity	Notes
1	1F	1029	Green room 01	15	Includes upright piano, table and chairs,sofa
2		1034	Dressing room 01	3	Includes mirror, table and chairs, toilet and shower
3		1036	Dressing room 02	3	Includes mirror, table and chairs, toilet and shower
4		1038	Dressing room 03	3	Includes mirror, table and chairs, toilet and shower
5		1040	Dressing room 04	3	Includes mirror, table and chairs, toilet and shower
6		1042	Company office 01	10	Includes table and chairs ,sofa
7		1050	Company office 02	10	Includes table and chairs.
8		1050A	Company office 03	10	Includes table and chairs.
9	B1F	B1020	Dressing room 07	26	Includes mirror, table and chairs, toilet and shower
10		B1025	Green room 02	25	Includes table and chairs ,sofa
11		B1026	Dressing room 08	14	Includes mirror, table and chairs, toilet and shower
12		B1028	Dressing room 09	14	Includes mirror, table and chairs, toilet and shower
13		B1043	Dressing room 10	12	Includes mirror, table and chairs and toilet
14		B1043A	Dressing room 11	12	Includes mirror, table and chairs and toilet

5-2 Orchestra Facilities

No.	Item	Quantity		Notes
1	Chair	100	*	
2	Ensemble stool	12	*	Rotate : 6 Unable to rotate : 6
3	Conductor' s chair	1		
4	Music stand	90	*	
5	Music stand light	110	*	White light, two brightness mode
6	Conductor' s podium(single layer)	1	*	WENGER L 120cm x W 115cm x H 25cm
7	Conductor' s stand	1	*	
8	Percussion table stand	4	*	
9	Acoustic shield	5	*	
10	Music stand Tray	10	*	
11	Endpin stopper	10	*	
12	Solo Musician' s PODIUM 130*60*16(cm)	2	*	
	Solo Musician' s PODIUM 100*60*16(cm)	2	*	
	Solo Musician' s PODIUM 130*60*30(cm)	10	*	
	Solo Musician' s PODIUM 100*60*30(cm)	8	*	

Items with * mark are shared with Opera House

5-3 Pianos (shared between four theatres)

No.	Item	Brand	Model Number	Quantity	Notes
1	Model-D Concert grand	Steinway & Sons	D-274	3	*
2	Concert grand	FAZIOLI	F308	1	*
3	Grand Piano	YAMAHA	C7XPE	1	*
4	Grand Piano	KAWAI	SK-6L	1	*
5	Harpsichord	J.C.NEUPERT	Hemsch	1	*
6	Celesta	Schiendmayer	5 ½ Octave Studio model	1	*
7	Upright Piano	YAMAHA	U3	1	*
8	Organ	ORGELBAU	Johannes KLAIS	1	*

Items with * mark are paid items. Please refer to the rate tables of National Kaohsiung Center for the Arts.

Important :

1. Pianos shared with four venues, booking in advance is required.
2. WeiWuYing's contract-signed piano technician must tune all pianos before performance. (Piano hire fees do not include tuning costs)
3. Extra material (any object touching the strings during the performance, including hands or palms) pianos are limited to YAMAHA C7XPE and KAWAI SK-6L, which should be restored and tuned by the venue's contracted tuner at the end of the performance (at the latest on the next day) at the expense of the applicant..
4. While WWY' s piano is in part of the performance, the Fog and Haze Machine can' t be used.

5-4 Loading Dock / Scenery Shipping Path / Loading Flow

5-4-1 West Dock

Playhouse and Opera House use the West Dock for loading and unloading. The dock is equipped with three hydraulic dock leveler that can be adjusted according to the required height.

Dock Dimension

Big loading dock: 7.25m (width) x 4.3m (height)

Small loading dock: 3.5m (width) x 4.3m (height)

Loading entrance and exit: 4.3m height from floor to top (Truck height limit 4.2m)

3.8m height from dock to grid area

Stage entrance and exit: minimum 4m (width) x 3.4m (height)

Height from dock to floor: 0.98m

※Notes for Container Transport:

Due to the limitation of the slope at the entry of the loading dock, the minimum height of the trailer's low bed should be higher than 100cm. Also, if the company hires a 40' high-cube container, the bed rack should be within the height of 135~140cm to accommodate the height of loading gate.

5-4-2 West Dock Handling equipment

2.5mt Electric Forklift x1

1.5mt Stand-Up Automatic Electric Forklift x1

3mt Manual Hydraulic Pallet Jack x2

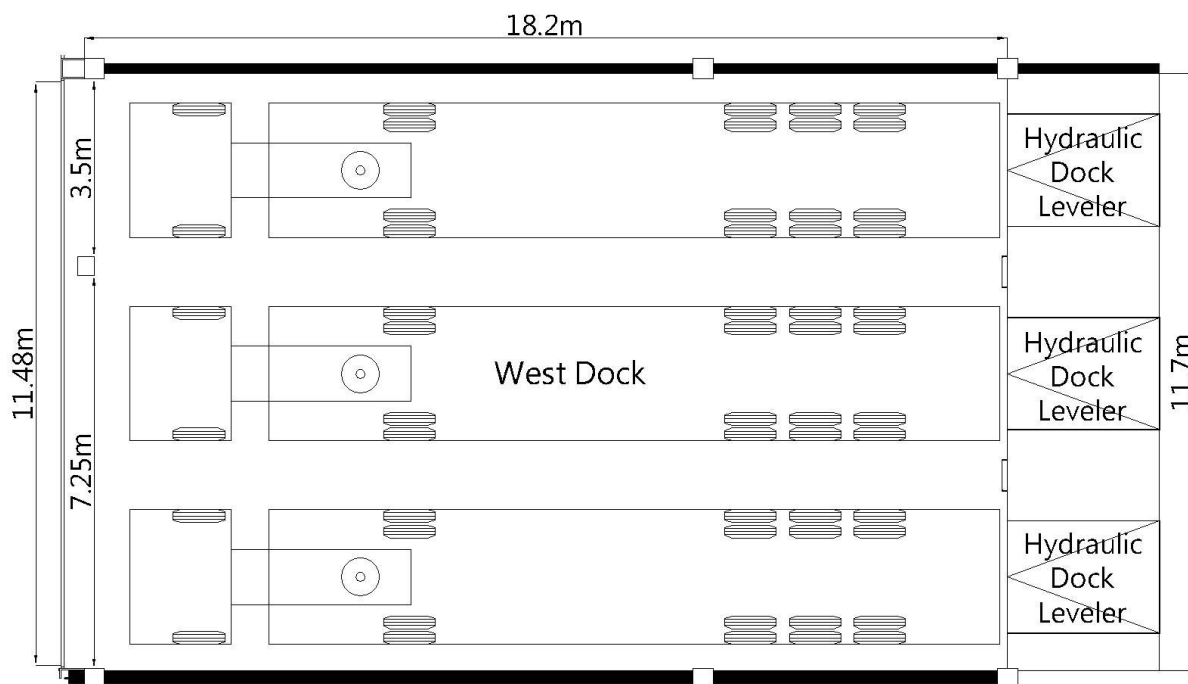

Figure 5.1- West Loading Dock Plan

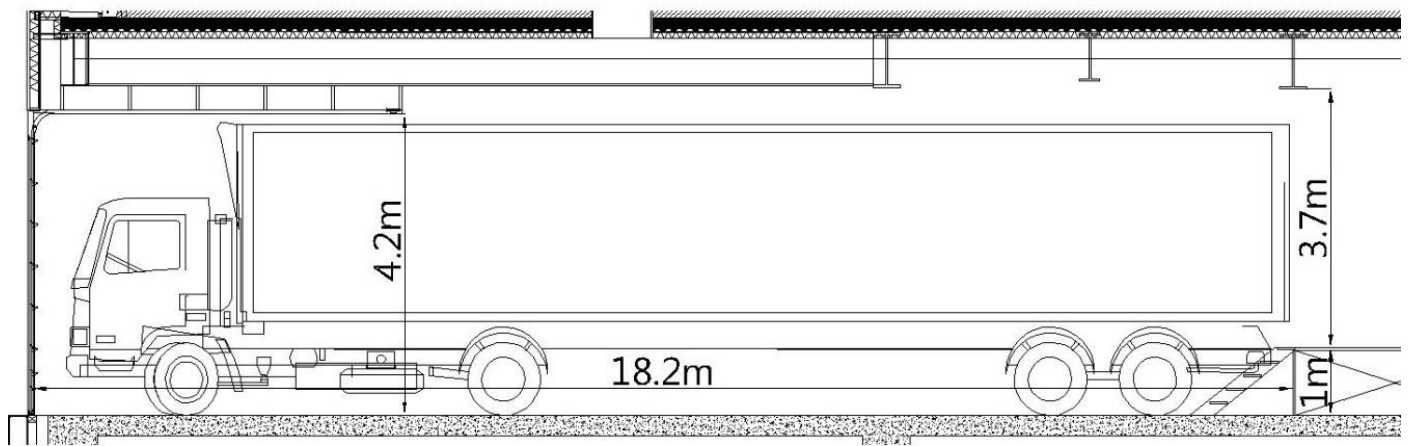
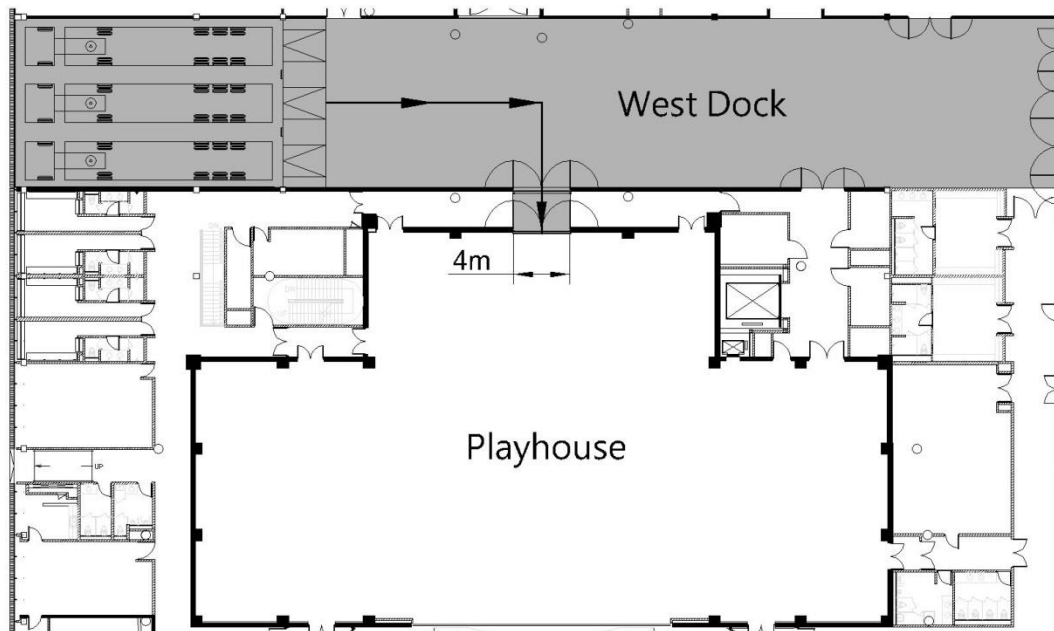

Figure 5.2- West Loading Dock Section

5-4-3 Loading Flow

Figure 5.3- Loading Flow



5-4-4 Hydraulic Dock Leveler

Capacity: 22.6mt

Area: 198cm (width) x 221.9cm (length)

Elevation: +/- 30.5cm

Quantity: 3

5-5 Other Facilities

5-5-1 Rehearsal Rooms

There is no rehearsal studio dedicated to the Playhouse. Additional rehearsal space is limited across the WeiWuYing. There are 13 different function and accommodated rehearsal studios, these available for hire between four major theatres. Requests should be discussed well in advance to determine availability. The hire fees please refer to the rate tables of National Kaohsiung Center for the Arts.

Room No.	Name	Dimension (Length x Width x Height / m)	Notes
1182	Medium Rehearsal Studio-02	11.4x10.8x3.8	1. Wooden floor covered gray color dance floor, Sound absorption wall x 2 side, Wall mount glassless mirrors x 2 side 2. Capacity : 50
1184	Medium Rehearsal Studio-03	11.1x10.8x4	1. Grand Piano, Wooden floor covered gray color dance floor, Sound absorption wall x 2 side, Wall mount glassless mirrors x 2 side 2. Capacity : 50
1186	Large Rehearsal Studio-04	17.5x12.1x3.9	1. Grand Piano, Wooden floor, black color dance floor, Wall mount glassless mirrors x 2 side, Fixed Ballet barre on the single sided wall mirror x 2 2. Capacity : 110
		Subsidiary space 6.6x8.8 x3	Rehearsal Studio-04 use only Green Room-01(With dressing room)
1192	Large Rehearsal Studio-05	19.3x12.2x3.9	1. Grand Piano, Wooden floor, black color dance floor, Wall mount glassless mirrors x 2 side, Fixed Ballet barre on the single sided wall mirror x 2 2. Capacity : 110
		Subsidiary space 6.6x8.8 x3	Rehearsal Studio-05 use only Green Room-02(With dressing room)
B1111	Small Rehearsal Studio-06	8x7.4x2.3	1. Upright piano, Chair, Music stand, Wooden floor, Sound absorption wall 2. Capacity : 25
B1112	Small Rehearsal Studio-07	5.2x4.4x2.3	1 Chair, Music stand, Wooden floor, Sound absorption wall 2 Capacity : 10
B1113	Small Rehearsal Studio-08	7.2x5x2.7	1. Chair, Music stand, Wooden floor, Sound absorption wall 2. Capacity : 15
B1114	Small Rehearsal Studio-09	5.2x3.7x2.7	1. Chair, Music stand, Wooden floor, Sound absorption wall 2. Capacity : 10
B1115	Small Rehearsal Studio-10	5.2x4.1x2.7	1. Chair, Music stand, Wooden floor, Sound absorption wall 2. Capacity : 10
B1116	Small Rehearsal Studio-11	5.2 x 4.1 x 2.7	1. Chair, Music stand, Wooden floor, Sound absorption wall 2. Capacity : 10
B304	Chorus Rehearsal Room	15.9x9.9x8.8	1. Grand Piano, Chair, Ensemble stool, Wooden floor, Sound absorption curtain 2. Capacity : 80
B313	Orchestra Studio	18.7x14.3x7.8	1. fixed auditorium < 84seats >, Grand Piano, Chair, Ensemble stool, Wooden floor, Sound absorption curtain 2. Capacity : 200

5-5-2 Carpentry Shop / Costume Shop / Laundry Room

National Kaohsiung Center for the Arts is equipped with basic production facilities, include Carpentry Shop, Costume Shop, and laundry rooms. Those for hire between four major theatres. The hire fees please refer to the rate tables of National Kaohsiung Center for the Arts.

Room No.	Name	Dimension (Length x Width x Height / m)	Notes
1002	Carpentry Shop	8.9x5.8x3	General welding facilities for repairs
1165	Costume Shop-01	5.9x10.2x3	Basic facilities for the maintenance of costume; Sewing machine, overlock machine and steam / iron equipment
1181	Costume Shop-02	5.8x11.8x3	
B1022	Costume Shop-03	5.4x3.7x2.5	
1163	Laundry Room-01	5.8x4.9x3	Washing machine, tumble dryers, sink and clothes folding table
B1019	Laundry Room-02	6x8.2x3	